













# Side-by-Side Refrigerator

## Use & Care Guide

 <b>Important Safety Instructions</b> .....	1-2
 <b>Installation</b> .....	3-6
 <b>Temperature Controls</b> .....	7-9
 <b>Fresh Food Features</b> .....	10-12
 <b>Freezer Features</b> .....	13
 <b>Ice and Water</b> .....	14-15
 <b>Water Filter</b> .....	16-17
 <b>Food Storage Tips</b> .....	18
 <b>Care and Cleaning</b> .....	19-22
 <b>Operating Sounds</b> .....	23
 <b>Troubleshooting</b> .....	24-27



# Important Safety Instructions

**Installer:** Please leave this guide with this appliance.

**Consumer:** Please read and keep this Use & Care Guide for future reference. This guide provides proper use and maintenance information.

Keep sales receipt and/or cancelled check as proof of purchase.

If you need service contact your local dealer for warranty information.

Have complete model and serial number identification of your refrigerator. This is located on a data plate inside the refrigerator compartment, on the upper left side. Record these numbers below for easy access.

Model Number \_\_\_\_\_

Serial Number \_\_\_\_\_

Date of Purchase \_\_\_\_\_

In our continuing effort to improve the quality and performance of our appliances, it may be necessary to make changes to the appliance without revising this guide.

## What You Need to Know About Safety Instructions

Warning and Important Safety Instructions appearing in this guide are not meant to cover all possible conditions and situations that may occur. Common sense, caution and care must be exercised when installing, maintaining or operating appliance.

Always contact your dealer, distributor, service agent or manufacturer about problems or conditions you do not understand.

## Recognize Safety Symbols, Words, Labels

### DANGER

**DANGER** – Immediate hazards which **WILL** result in severe personal injury or death.

### WARNING

**WARNING** – Hazards or unsafe practices which **COULD** result in severe personal injury or death.

### CAUTION

**CAUTION** – Hazards or unsafe practices which **COULD** result in minor personal injury or property damage.

### DANGER

**To reduce risk of injury or death, follow basic precautions, including the following:**

**Important:** Junked or abandoned refrigerators are still dangerous – even if they sit out for “just a few days.” If you are getting rid of your old refrigerator, please follow the instructions below to help prevent accidents.

*Before you throw away your old refrigerator or freezer:*

- Take off the doors.
- Leave the shelves in place so children may not easily climb inside.

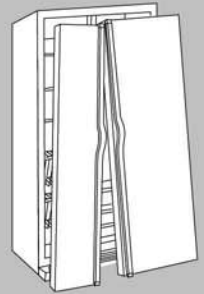

Always disconnect refrigerator from electrical supply before attempting any service.

Plug must be accessible



# Important Safety Instructions

## ⚠ WARNING

**To reduce risk of fire, electric shock, serious injury or death when using your refrigerator, follow these basic precautions, including the following:**

1. Read all instructions *before* using the refrigerator.
2. Observe all local codes and ordinances.
3. Be sure to follow earthing instructions.
4. Check with a qualified electrician if you are not sure this appliance is properly earthed.
5. **Do not** earth to a gas line.
6. **Do not** earth to a cold-water pipe.
7. Refrigerator is designed to operate on a separate 220-240 volt, 10 amp., 50 HZ cycle line.
8. **Do not** modify plug on power cord. If plug does not fit electrical outlet, have proper outlet installed by a qualified electrician.
9. **Do not** use a two-prong adapter, extension cord or power strip.
10. **Do not** tamper with refrigerator controls.
11. **Do not** service or replace any part of refrigerator unless specifically recommended in Use & Care Guide or published user-repair instructions. **Do not** attempt service if instructions are not understood or if they are beyond personal skill level.
12. *Always* disconnect refrigerator from electrical supply *before* attempting any service. Disconnect power cord by grasping the plug, not the cord.
13. Install refrigerator according to Installation Instructions. All connections for water, electrical power and earthing must comply with local codes and be made by licensed personnel when required.
14. Keep your refrigerator in good condition. Bumping or dropping refrigerator can damage refrigerator or cause refrigerator to malfunction or leak. If damage occurs, have refrigerator checked by qualified service technician.
15. A qualified service technician must replace worn power cords and/or loose plugs.
16. *Always* read and follow manufacturer's storage and ideal environment instructions for items being stored in refrigerator.
17. Your refrigerator **should not** be operated in the presence of explosive fumes.
18. Children **should not** climb, hang or stand on any part of the refrigerator.
19. Clean up spills or water leakage associated with water installation.
20. The appliance is not intended for use by young children or infirm persons without supervision.
21. Young children should be supervised to ensure that they **do not** play with the appliance.

## Installing Your Refrigerator

These instructions were provided to aid you in the installation of your unit. The manufacturer cannot be responsible for improper installation.

### Steps to Follow...

**A qualified engineer must connect refrigerator in accordance with these installation instructions.**

Measure door opening and depth and width of refrigerator. Remove handles or doors if required. Engineer must also do the following:

1. Follow local water and electrical company connection regulations.
2. Complete water supply connection before electrical supply connections.

**Service to or replacement of power cord must be performed by a qualified engineer.**

#### Note:

When writing or calling about a service problem, please include the following information:

- a. Your name, address and telephone number;
- b. Model number and serial number;
- c. Name and address of your dealer or engineer;
- d. A clear description of the problem you are having;
- e. Proof of purchase (sales receipt)

**SAVE THESE INSTRUCTIONS FOR FUTURE REFERENCE**



# Installation

## ⚠ WARNING

To be done by a qualified engineer only.

## Location

- **Do not** install refrigerator near oven, radiator or other heat source. If not possible, shield refrigerator with cabinet material.
- **Do not** install where temperature falls below 13° C or rises above 43° C. Malfunction may occur at this temperature.
- Refrigerator is designed for indoor household application only.

## Measuring the Opening

When installing your refrigerator allow 13 mm space at top, 19 mm space behind machine compartment cover (located in the rear). Allow 6 mm space on both sides of the refrigerator for proper air circulation, ease of installation, and leveling. If the refrigerator is placed with the door hinge side against the wall, you may want to allow additional space so the door can be opened wider.

### 60 cm deep models

**Note:** Trim corners of countertop to a 45° angle if countertop has 25 mm overhang. Provide 5 mm clearance on both sides of refrigerator, and allow 7 mm on top for ease of installation and leveling. No minimum clearance is required at the rear of the cabinet.

Subflooring or floor coverings (i.e. carpet, tile, wood floors, rugs) may make your opening smaller than anticipated.

Some clearance may be gained by using the leveling procedure under *Leveling*.

**Important:** If refrigerator is to be installed into a recess where the top of the refrigerator is completely covered, use dimensions from floor to top of hinge cap to verify proper clearance.

## Transporting Your Refrigerator

- **NEVER** transport refrigerator on its side. If an upright position is not possible, lay refrigerator on its back. Allow refrigerator to sit upright for approximately 30 minutes *before* plugging it in to assure oil returns to the compressor. Plugging refrigerator in immediately may cause damage to internal parts.
- Use an appliance dolly when moving refrigerator. **ALWAYS** truck refrigerator from its side or back—**NEVER** from its front.
- Protect outside finish of refrigerator during transport by wrapping cabinet in blankets or inserting padding between the refrigerator and dolly.
- Secure refrigerator to dolly firmly with straps or bungee cords. Thread straps through handles when possible. **Do not** over-tighten. Over-tightening restraints may dent or damage outside finish.

## How to Remove and Replace Door and Hinges

### ⚠ WARNING

Contact a qualified engineer to perform this task.

## How to Connect the Water Supply (select models)

### ⚠ WARNING

Contact a qualified engineer to perform this task.



# Installation

## Handle Installation

If not installed, the handle is located in the interior of the fresh food section or attached to the back of your refrigerator.

Remove and discard handle packaging and tape.

Handle design varies from refrigerator to refrigerator. Please reference the appropriate instructions for your model below.

### Front Mount Handle (select models)

#### Materials Needed:

- Gloves to protect hands
- Phillips screwdriver
- Plastic door removal card (or 0.1 cm thick plastic card), retain the card for offset handle use.

#### Attach Extensions to Handle: (select models)

1. Align handle and extension as shown.
2. Place extension in handle opening.
3. Apply slight pressure to both sides of the extension piece.
4. Slide extension until it stops on inside edge of handle.

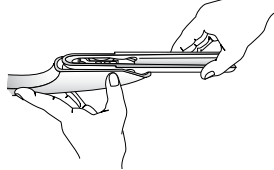

#### To Install:

1. The handles are to be oriented as shown.
2. Align door handle with the door studs.
3. Ensure the large hole in the mounting clip is positioned *down* on both ends of the handle.

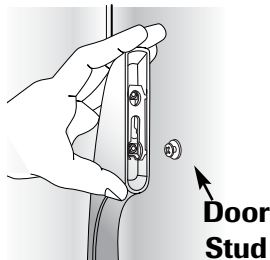
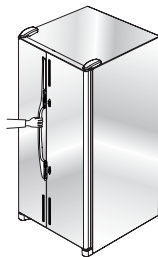

4. Rotate the handle so that the handle is flat against the door.
5. Grasp the handle firmly and slide *down*.

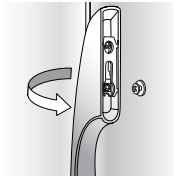

#### To Remove:

1. Grasp the lower part of the handle firmly, slide *up*, lift and remove from surface.

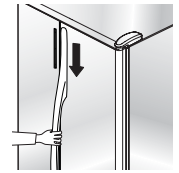

## Offset Handles

#### To Install:

1. Align fresh food handle with trim retainer and door clip.
2. Make sure the tabs of the handle clip are below the tabs of the door clip.
3. Rotate the handle so that the handle is flat against the door.
4. The tab on the lower part of the handle will align with the hole in the handle cap.
5. Slide handle upward until it clicks.
6. Snap top of handle into trim retainer clip.
7. Repeat for freezer handle.

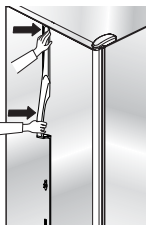
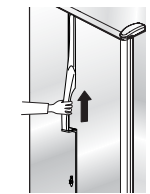
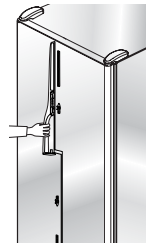

#### To Remove:

1. Protect the area above the handle trim with tape. Insert the tip of a flat blade screwdriver between the handle trim and door panel. Carefully pry the trim away from the door panel.
2. Pull trim free from the trim retainer.
3. Insert door removal card (or 0.1 cm thick plastic card) between the handle and door panel (approximately 3.8 cm).
4. Grasp the handle firmly and pull downward to remove.
5. Repeat for freezer handle.

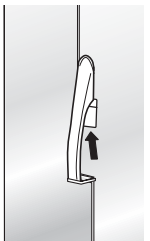



# Installation

## Full-Length Aluminum Handles

### To Install:

1. Release top door trim by removing Phillips screws from top of fresh food door and retain screws for later use.
2. Align notches on back of handle with retaining clips on doors. Insert clips into notches and slide handle down until it contacts bottom trim.
3. Replace top door trim and Phillips screws.
4. Repeat instructions 1-3 to install other handle.

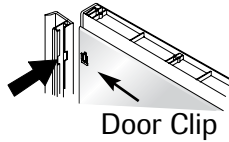
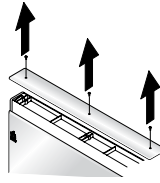

### To Remove:

1. Release top door trim by removing Phillips screws from top of fresh food door and retain screws for later use.
2. Grasp handle firmly with both hands. Slide handle upward approximately 1.9 cm to release.
3. Repeat instructions 1-3 to remove other handle.

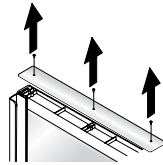
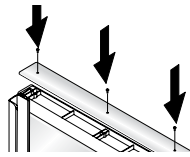

### To Reinstall:

1. Repeat in reverse order.

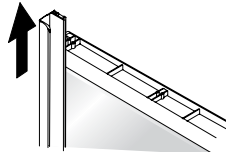

## 6 mm Panel Dimensions:

Extended Door Models	Panel Height	Panel Width
Fresh food door	169.5 cm	48.1 cm
Upper freezer door (dispenser)	46.0 cm	35.4 cm
Lower freezer door (dispenser)	81.5 cm	35.4 cm
Freezer door (non-dispenser)	169.5 cm	35.4 cm

### To Install:

1. Remove top trim screws with a Phillips screwdriver to remove top trim.
2. Slide handle upward until loose. Pull handle from door.
3. Remove door retainer clips with a 1/4" hex head driver.
4. Slide bottom of panels into bottom door trim until hinge side of decorator panel rests under hinge side trim. **Important:** Tape tops of panels to door to prevent panels from falling.
5. Reinstall door retainer clips with a 1/4" hex head driver.
6. Reinstall handle by inserting retaining clips on door into notches on back of handle. Slide handle *down* until it contacts bottom trim.
7. Remove tape from tops of panels *before* reinstalling top door trim with Phillips screw removed in step 1.

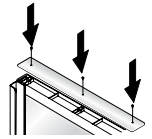
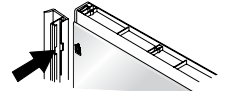
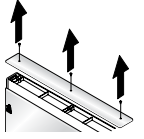

### To Remove:

1. Perform step 1 as explained in the installation instructions. **Important:** Tape tops of panels to door to prevent panels from falling.
2. Perform steps 2 & 3. Remove tape to slide panels out of door trim. Continue with steps 5, 6, and 7 to replace handle and trim.

## ⚠ WARNING

To avoid possible injury and damage to property, tape decorative panels (select models) securely into place *before* removing door handles.

## ⚠ CAUTION

To avoid personal injury or property damage, observe the following:

- Refrigerator panels **should not** weigh more than 14 kilograms and freezer panels should not weigh more than 7 kilograms.
- Protect soft vinyl or other flooring with cardboard, rugs, or other protective material.
- Protect hands and arms by wearing gloves.

## Decorator Door Panels

### Procedure:

- To protect door surfaces from being scratched, cover back edges of decorator panels by placing masking tape along back edges.
- Save all screws and reuse in original locations.

## Euro Handles

This handle style is installed at the factory.

### Materials Needed:

- 3/32" Allen wrench

### To Remove:

- Remove set screw from handle mounting post using 3/32" Allen wrench.
- Repeat the procedure on all posts to remove the handle.

### To Replace:

- Align handle with the mounting posts.
- Fully tighten all set screws to secure handle in place.

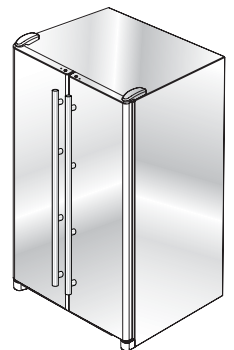



# Installation

## Leveling

### ⚠ CAUTION

To protect personal property and refrigerator from damage, observe the following:

- Protect vinyl or other flooring with cardboard, rugs, or other protective material.
- **Do not** use power tools when performing leveling procedure.

### Notes:

- Complete any required water supply connection *before* leveling.
- Some models only have adjustment screws **(A)**.

### Materials Needed:

- 3/8" hex head driver
- Carpenter's level.

1. Remove toe grille.

- Grasp firmly and pull outward to unclip.

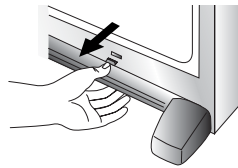

2. Using hex head driver, turn the front adjustment screws **(A)** on each side to raise or lower the front of the refrigerator (see illustration below).



3. Select models also have rear adjustment screws **(B)**. Using the hex head driver, turn each of these adjustment screws **(B)** to raise or lower the rear of the refrigerator.

4. Using a carpenter's level, make sure front of refrigerator is 1/4" (6 mm) or approximately 1/2 bubble higher than back of refrigerator and that the refrigerator is level from side to side.

5. Turn stabilizing legs **(C)** clockwise until firmly against floor.

6. Turn adjustment screws **(A)** counterclockwise to allow the full weight of the refrigerator to rest on the stabilizing legs.

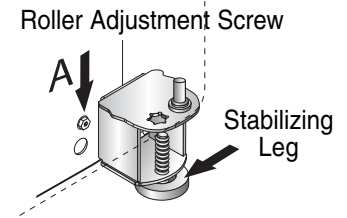

7. If required, correct rocking of refrigerator by turning rear adjustment screw clockwise to raise rocking corner. If doors are uneven, do the following:

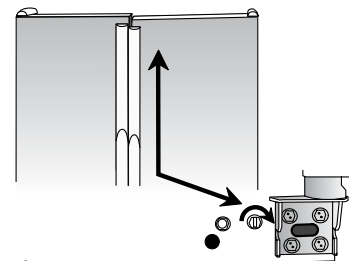

- Determine which door needs to be raised.
- Turn front roller adjustment screw **(A)** clockwise to raise front corner of door.
- If one refrigerator door has reached the limit of its adjustment range and doors are still not level, raise or lower the opposite door by turning roller adjustment screw clockwise or counterclockwise.
- Check with level to verify 6 mm tilt to the back for proper door closure.
- If refrigerator is aligned and stable, replace toe grille.
- Align the toe grille mounting clips with the lower cabinet slots.
- Push the toe grille firmly until it snaps into place.



# Temperature Controls

## Touch Temperature Controls (select models, style varies by model)

The controls are located at the top front of the refrigerator compartment.

### Control



### Initial Control Settings

After plugging the refrigerator in, set the controls.

- Pressing the or pads adjusts the controls to the desired setting.
- Set the Freezer control on **4**.
- Set the Refrigerator control on **4**.
- Let the refrigerator run at least 8 to 12 hours *before* adding food.

### Warm Cabinet Surfaces

At times, the front of the refrigerator cabinet may be warm to the touch. This is a normal occurrence that helps prevent moisture from condensing on the cabinet. This condition will be more noticeable when you first start the refrigerator, during hot weather and after excessive or lengthy door openings.

### Adjusting the Controls

- 24 hours after adding food, you may decide that one or both compartments should be colder or warmer. If so, adjust the control(s) as indicated in the *Temperature Control Guide* table.
- Except when starting the refrigerator, **do not** change either control more than *one* number at a time.
- Allow 24 hours for temperatures to stabilize.

### Temperature Control Guide

<b>Refrigerator too warm</b>	Set the Refrigerator control to next higher number by pressing the  pad.
<b>Refrigerator too cold</b>	Set the Refrigerator control to next lower number by pressing the  pad.
<b>Freezer too warm</b>	Set the Freezer control to next higher number by pressing the  pad.
<b>Freezer too cold</b>	Set the Freezer control to next lower number by pressing the  pad.
<b>Turn control OFF</b>	Press the <b>Freezer</b> or <b>Refrigerator</b> pad until a dash “-” appears in the display.

## Trisensor Climate Control (select models)

The control is located at the top front of the fresh food compartment or cabinet front.

### Control

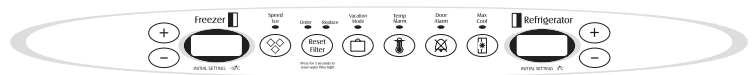

### Facade Control

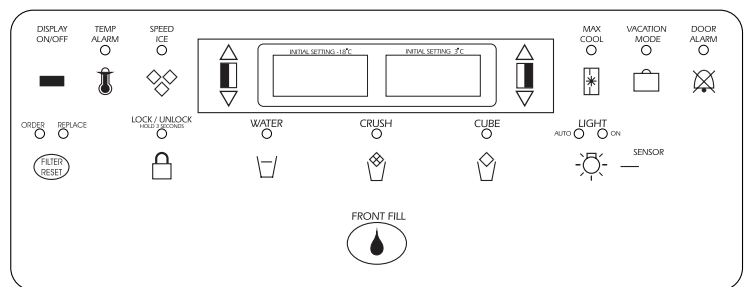

### Initial Temperature Setting

Temperatures are preset at the factory at 3° C in the fresh food compartment and -18° C in the freezer compartment.

### Adjusting the Control

24 hours after adding food, you may decide that one or both compartments should be colder or warmer. If so,





# Temperature Controls

adjust the control as indicated in the *Temperature Control Guide* below.

- The first touch of the  $\oplus / \triangle$  or  $\ominus / \nabla$  pads shows the current temperature setting.
- The display will show the new setting for approximately *three* seconds, and then return to the actual temperature currently within that compartment.
- **Do not** change either control more than *one* degree at a time. Allow temperature to stabilize for 24 hours *before* making a new temperature adjustment.

## Temperature Control Guide

<b>Refrigerator too cold</b>	Set the Refrigerator control to next higher number by pressing the $\oplus / \triangle$ pad.
<b>Refrigerator too warm</b>	Set the Refrigerator control to next lower number by pressing the $\ominus / \nabla$ pad.
<b>Freezer too cold</b>	Set the Freezer control to next higher number by pressing the $\oplus / \triangle$ pad.
<b>Freezer too warm</b>	Set the Freezer control to next lower number by pressing the $\ominus / \nabla$ pad.
<b>Turn refrigerator OFF</b>	Press the <b>Freezer</b> $\oplus / \triangle$ pad until “-” appears in the display. Press either the <b>Freezer</b> or <b>Refrigerator</b> $\ominus / \nabla$ pad to turn back on.

## Speed Ice

When activated, Speed Ice reduces the freezer temperature to the optimum setting for 24 hours in order to produce more ice. **Important:** When the Speed Ice feature is in operation, the  $\oplus / \triangle$  and  $\ominus / \nabla$  pads for the Freezer control will not operate.

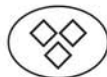

## Reset Filter (select models)

When a water filter has been installed in the refrigerator, the yellow Order light will illuminate when 90 percent of the volume of water for which the filter is



rated has passed through the filter OR 11 months have elapsed since the filter has been installed.

The red Replace light will illuminate when the rated volume of water has passed through the filter OR 12 months have elapsed since the filter was installed. A new filter should be installed immediately when the Replace light is illuminated.

After replacing the filter, press and hold the **Reset Filter** pad for *three* seconds. The Order and Replace lights will go off.

## Vacation Mode



The Vacation Mode feature causes the freezer to defrost less frequently, conserving energy. The Vacation Mode indicator light will illuminate when the feature is activated. To deactivate, press the **Vacation Mode** pad again OR open either door. The indicator light will go off.

## Notes:

- Door openings will not deactivate Vacation Mode for approximately one hour after activation.
- If vacationing for more than a few days, see the *Preparing for Vacation* section, page 22.

## Temp Alarm



The Temp Alarm system will alert you if the freezer or fresh food temperatures exceed normal operating temperatures due to a power outage or other event. When activated, the Temp Alarm light will illuminate.

If the freezer or fresh food temperatures have exceeded these limits, the display will alternately show the current compartment temperatures and the highest compartment temperatures reached when the power was out. An audible alarm will sound repeatedly.

Press the **Temp Alarm** pad *once* to stop the audible alarm. The Temp Alarm light will continue to flash and the temperatures will alternate until the temperatures have stabilized.

To turn off Temp Alarm, press and hold the **Temp Alarm** pad for *three* seconds. The indicator light will go off.



# Temperature Controls

## Door Alarm



The Door Alarm will alert you when one of the doors has been left open for five continuous minutes. When this happens, an audible alarm will sound every few seconds until the door is closed OR the **Door Alarm** pad is pressed to deactivate the feature.

## Max Cool

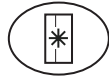

When activated, Max Cool causes the refrigerator and freezer temperatures to drop to the minimum settings on the control. This cools down the refrigerator and freezer after extended door openings or when loading the refrigerator or freezer with warm food. **Important:** When the Max Cool feature is in operation, the  $\oplus/\triangle$  and  $\ominus/\nabla$  pads for the refrigerator and freezer controls will not operate.

To activate, press the **Max Cool** pad. Max Cool will deactivate automatically after 12 hours, OR press the **Max Cool** pad to deactivate the feature.

## Display On/Off (select models)

Temperature readout alternates On/Off. 

## User Preferences

Access the User Preferences menu to:

- Change the temperature display from °F to °C
- Enable or disable audible alarms.
- Adjust the light level at which the Dispenser Auto Light will illuminate (when this feature is activated on the ice and water dispenser) (select models)
- Activate the Sabbath Mode

To access the User Preferences menu, press and hold the **Door Alarm** pad for *three* seconds. When in the User Preferences mode, a short title for the feature will appear in the Freezer temperature display and the

feature status will appear in the refrigerator display.

1. Use the **Freezer** up and down control to scroll through the features.
2. When the desired feature is displayed, use the **Refrigerator** up and down control to change the status.
3. When changes are complete, press the **Door Alarm** pad for *three* seconds OR close the refrigerator door.

## Temperature Display (F\_C)

Change the display to show temperatures in degrees Fahrenheit or degrees Celsius.

## Alarm (AL)

When the Alarm mode is OFF, all audible alarms will be disabled until the feature is turned on.

## Auto Light Level Selection (LL) (select models)

This setting adjusts the light level at which the dispenser light will illuminate when the sensor detects that the light levels in the room are low. Setting 1 is the darkest light level setting, setting 9 is the lightest light level setting. **Important:** The Auto Light (select models) must be activated on the ice and water dispenser control to take advantage of this option.

## Sabbath Mode (SAB)

When the Sabbath Mode is ON, all control lights and the night light will be disabled until the feature is turned OFF. This feature does not disable the interior lights. Press any pad to restore the control lights.

## Warm Cabinet Surfaces

At times, the front of the refrigerator cabinet may be warm to the touch. This is a normal occurrence that helps prevent moisture from condensing on the cabinet. This condition will be more noticeable when the refrigerator is first started, during hot weather and after excessive or lengthy door openings.



# Fresh Food Features

## Shelves

### ⚠ CAUTION

To avoid personal injury or property damage, observe the following:

- **Never** attempt to adjust a shelf that is loaded with food.
- Confirm shelf is secure *before* placing items on shelf.
- Handle tempered glass shelves carefully. Shelves may break suddenly if nicked, scratched, or **exposed to sudden temperature change.**

Your refrigerator has either Spillsaver™ or non-sealed shelves. Spillsaver™ shelves have a spill retainer edge which allows for easier clean up and some are equipped with the EasyGlide™ slide out feature. To slide out (select models), grasp the front of the shelf and pull forward. Push in the shelf to return to the original position.

### To Remove a Shelf:

- Slightly tilt up the front and lift up the rear of the shelf, then pull the shelf straight out.

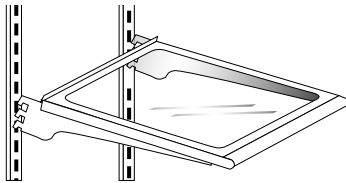

### To Lock the Shelf Into Another Position:

- Tilt up the front edge of the shelf.
- Insert the hooks into the desired frame openings and let the shelf settle into place.
- Be sure the shelf is securely locked at the rear.

The Crisper Top serves as the lower fresh food shelf.

### To Remove the Crisper Top:

- Remove drawers as indicated (see page 12).
- Place hand under the frame to push up the glass. Lift glass out.
- To install, repeat above instructions in reverse order.

## Elevator™ Shelf (select models)

The Elevator™ Shelf is equipped with a spill-retaining edge and the EasyGlide™ slide-out feature. It can be adjusted up or down without unloading.

### To Slide Out Elevator™ Shelf:

- Grasp the front of the shelf and pull forward.
- Push the shelf in to return to original position.

### To Adjust the Elevator™ Shelf:

- Pull out the knob on the crank handle.
- Rotate the crank *clockwise* to raise the shelf, and *counterclockwise* to lower the height of the shelf.

### To Remove Elevator™ Shelf:

- Completely unload the shelf and pull the shelf forward.
- Pull until the shelf stops.
- Press *up* on the tabs located underneath its outside edges and continue pulling forward until the shelf is clear of the frame.

### To Replace Elevator™ Shelf:

- Align the shelf to the frame and push it all the way back. It is not necessary to press up on the tabs for reinstallation.

In ordinary use, the Elevator™ Shelf frame assembly does not require removal. Though unlikely, and not recommended, the correct removal procedure is as follows:

### To Remove Frame Assembly:

- Unload the shelf completely.
- Slide the shelf forward about 5.1 cm and manually move the two rear latches toward the shelf center.
- While supporting the entire shelf and frame from underneath, lift slightly and rotate the assembly approximately 30° to allow the rear mechanism to clear the vertical rear side rails.
- The entire assembly can then be moved forward and clear of the refrigerator compartment.

### To Reinstall Frame Assembly:

- Reverse the removal procedure. Be sure the shelf is in a level position. When the sliding shelf is pushed to the rear, it will reposition the rear latches to their correct operating position.

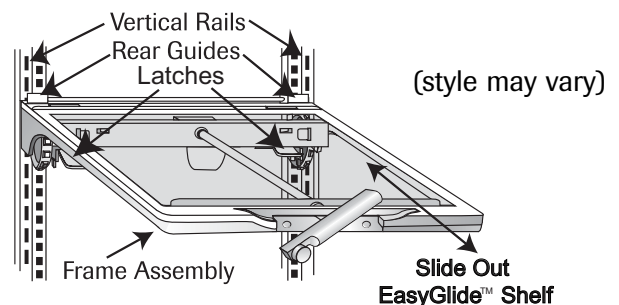



# Fresh Food Features

## Door Storage

### Beverage Chiller™/MiniChiller™ (select models)

The Beverage Chiller™ and MiniChiller™ keep beverages and other items colder than the rest of the fresh food compartment. An air inlet directs air from the freezer into the chiller(s).

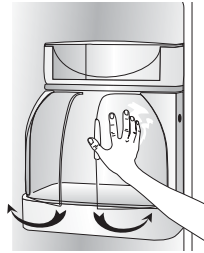

#### Controls

The chiller control is located on the left side wall of the fresh food compartment. Turn the control *clockwise* for colder temperature.



#### To Remove Chiller(s):

- Unload the chiller(s).
- Slide the assembly up and pull straight out.

**Note:** If the chiller is installed directly under the dairy center or a door bucket, the bucket or dairy center will need to be removed before removing the chiller.

#### To Install Chiller(s)

- Align one of the air inlet holes with the hole cut out on the door.
- Slide the assembly in and down so that the hooks are firmly seated on the door liner.

**Note:** The chillers will not operate properly if the air intake hole is not aligned with the control location.

## Dairy Center

The Dairy Center provides convenient door storage for spreadable items such as butter and margarine. This compartment can be moved to several different locations to accommodate storage needs.

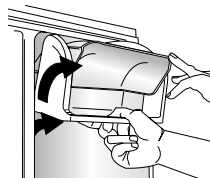

#### To Remove:

- Slide dairy center up and pull out.

#### To Install:

- Slide assembly in and down so that the hooks are firmly seated on the door liner.

#### To Remove Dairy Door:

- Press in sides of dairy door and pull out.

#### To Install Dairy Door:

- Slide sides of dairy door inside dairy center until hinge points snap into place.

## Adjustable Deep Tilt-Out Door Buckets (select models)

The Adjustable Deep Tilt-Out Door Bucket provides easy access to food items stored in the door.

#### To Remove Bucket:

- Tilt bucket out.
- Pull straight out of the bracket.

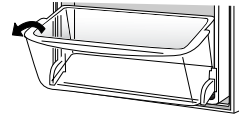

#### To Install Bucket:

- Tilt the front of the bucket down slightly.
- Slide into bracket and tip upright.

#### To Move Bucket Frame to Another Location:

- Remove bucket.
- Lift bracket up and pull straight out.

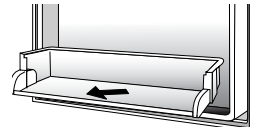

Place the bracket in a new location.

## Door Buckets

Door Buckets can be moved to meet individual storage needs.

#### To Remove:

- Lift bucket up and pull straight out.

#### To Install:

- Place bucket in desired door liner retainer, push down until bucket stops.

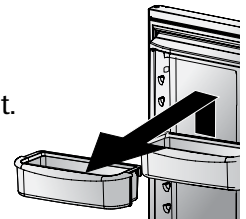



# Fresh Food Features

## Storage Drawers

### Humidity-Controlled Crisper Drawers

The Crisper Drawers provide a higher humidity environment for fresh fruit and vegetable storage.

#### Controls

The crisper controls regulate the amount of humidity in the crisper drawer. Slide control toward the **Fruit** setting for produce with outer skins. Slide control toward the **Vegetables** setting for leafy produce.



#### To Remove:

- Pull drawer out to full extension. (On select models, press tabs toward oneself to release drawer from rails.) Tilt up front of drawer and pull straight out.

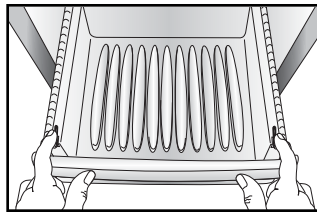

#### To Install:

- Insert drawer into frame rails and push back into place.

**Note:** For best results, keep the crispers tightly closed.

### Temperature-Controlled Drawer (select models)

This drawer can be used for storage of miscellaneous items.

The drawer features a control that regulates the air temperature in the drawer. Set the control to **Cheese** to provide normal refrigerator temperature. Use the **Meats** setting for meats.

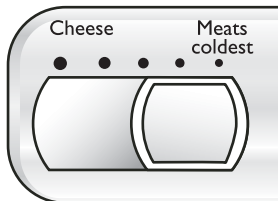

## Accessories

### Grip Pads (select models)

The Grip Pads prevent objects from sliding in the door buckets. Grip Pads are removable and are top-rack dishwasher safe for easy cleaning.

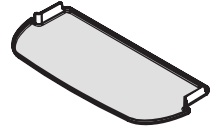

### Covered Storage Bucket (select models)

The Storage Bucket has a lid and removable egg tray. When tray is removed, bucket will accept items such as a standard egg carton, ice, etc.

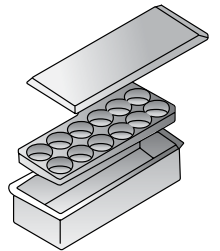

### Tall Bottle Retainer/Snagger (select models)

The Tall Bottle Retainer prevents tall bottles from tipping forward. The Retainer can be placed above any removable door bucket.

The Snagger attached to the Tall Bottle Retainer keeps bottles and other containers in place when the door is opened or closed. Adjust the Snagger by sliding from side to side.

### Egg Tray With Handle (style may vary/select models)

The Egg Tray with Handle holds a “dozen-plus” eggs. It can be removed to carry to a work area or to be washed.

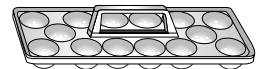



# Freezer Features

## Shelves and Baskets

### Fixed Freezer Shelf

#### To Remove Clip-Mounted Shelves:

- Lift shelf from wall mounting clips and pull left side of shelf out of wall mounting holes.

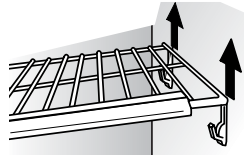

#### To Install Clip-Mounted Shelves:

- Place left side of shelf in mounting holes and press down into wall mounting clips.

### Shelves

Shelves can be removed to meet individual storage needs.

#### To Remove Shelf:

- Snap right side of shelf up from cabinet railing and slide to right.

#### To Install Shelf:

- Replace shelf in left side cabinet railing. Snap shelf into right side cabinet railing.

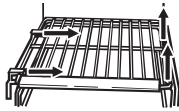

### Baskets and Drawers

Baskets and drawers slide out for easy access of items in back.

#### To Remove:

- Pull out to its full extension. Lift up front of basket and remove.



#### To Install:

- Slide basket or drawer into cabinet railing. Lift up front of basket or drawer, and slide to the back of refrigerator.

### Ice Storage Bin

The Ice Storage Bin is located below the automatic ice maker.

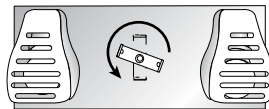

#### To Remove:

- Raise ice maker arm to deactivate ice maker. Lift front of bin and pull out to its full extension. Lift up front of bin and remove.

#### To Install:

- Slide bin into railing below ice maker until bin locks into place. Drop ice maker arm to activate ice maker.

**Important:** Ice bin must be locked in place for proper ice dispensing. Turn auger driver behind bin *counterclockwise* (as shown) to properly align ice bin with auger driver.

## Door Storage

### Adjustable Door Buckets

Door Buckets can be moved to meet individual storage needs.

#### To Remove:

- Lift the door bucket up until it clears the retainers on the door liner, then pull the door bucket straight out.

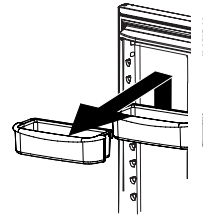

#### To Install:

- Slide bucket in above desired door liner retainer and push down until bucket stops.

### Fixed Door Bucket (select models)

The Fixed Door Bucket is located in the upper section of the freezer door.

**Important:** Fixed door bucket is not adjustable. If bucket is removed, freezer light will not deactivate when door is closed.

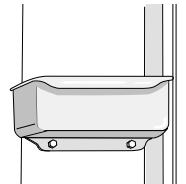

### Tilt-out Door Buckets (select models)

The Tilt-Out Door Bucket provides easy access to food items stored in the door.

#### To Remove Bucket:

- Tilt bucket out.
- Pull straight out of the frame.

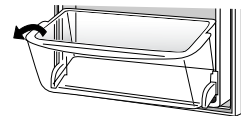

#### To Install Bucket:

- Tilt the front of the bucket down slightly.
- Slide into frame and tip upright.

#### To Move Bucket Frame to Another Location:

- Remove bucket.
- Lift frame up and pull straight out.

Slide the frame in and down into the new location.

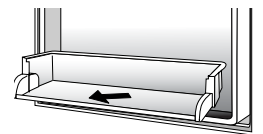

### Drop-Down Freezer Door Baskets (select models)

These baskets provide convenient storage space for frozen food items that tend to shift, such as bagged vegetables.

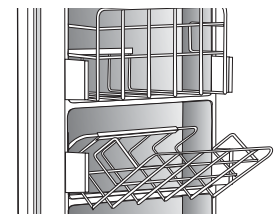



# Ice and Water

## Dispenser Features (select models)

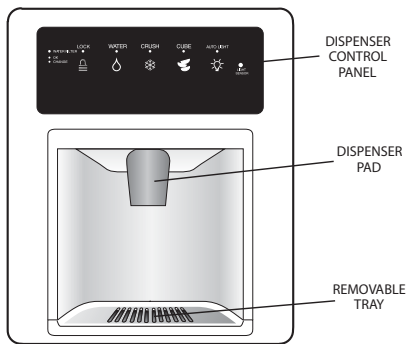

### Dispenser Light (select models)

A light activates within the dispenser area at full power when dispensing ice or water with the main dispenser pad.

### Dispenser Pad

The Dispenser Pad is located on the back wall of the dispensing area. When the dispenser pad is pressed, the selection chosen on the dispenser control panel will dispense.

### Removable Tray

The Removable Tray at the bottom of the dispenser area is designed to collect small spills and may be easily removed for cleaning and emptying purposes.

**Important:** Removable tray does not drain. **Do not** allow tray to overflow. If it does, remove tray and wipe up overflow.

## Water Dispenser Operation

### ⚠ CAUTION

To avoid personal injury or property damage, observe the following:

- **Do not** put fingers, hands or any foreign object into dispenser opening.
- **Do not** use sharp objects to break ice.
- **Do not** dispense ice directly into thin glass, fine china or delicate crystal.

## Ice Maker Operation

- To turn ice maker On, push arm *down* from locked position.

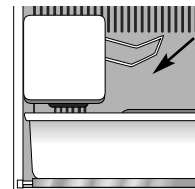

- Lift arm *up* and lock into position to turn ice maker Off.

**Note:** During initial use of water dispenser, allow up to one minute delay while water tank fills before water dispenses. Discard first 10-14 glasses of water after initially connecting refrigerator to household water supply and after extended periods of nonuse.

### To Use Dispenser Pad:

- Choose water selection from dispenser control panel.
- Press sturdy, wide-mouthed container against dispenser pad. When dispensing crushed ice, hold container as close to chute as possible to reduce spraying.
- Release pressure on dispenser pad to stop water dispensing. A small amount of water may continue to dispense and collect in dispenser tray. Large spills should be wiped dry.



# Ice and Water

## Dispenser Control (select models) (control features vary by model)

### Ice Dispenser Operation



#### To Dispense Ice:

- Select **Crushed** or **Cubes** ice mode by pushing button on dispenser control panel. A green light above button indicates mode selection.
- Press container against dispenser pad. When dispensing crushed ice, hold container as close to chute as possible to reduce spraying.



#### Notes:

- Mode may not be changed while ice dispenser is in operation.
- If dispenser (select models) is active for more than 90s, an automatic lock out sensor will shut down power to dispenser area. See *Dispenser Lock* for unlocking information.

### Dispenser Lock (select models)

The Dispenser Lock prevents ice or water from being dispensed.



#### To Lock Dispenser:

- Press and hold the **Lock** button for *three* seconds. A green indicator light above button will illuminate when the dispenser is locked.

#### To Unlock Dispenser:

- Hold the **Lock** button for *three* seconds. The green indicator light above button will go out.

### Water Filter Status Indicator Light (select models)



The Water Filter Status Indicator Light serves as a reminder to replace the water filter. A green light indicates that the filter is in good condition. A red light indicates the filter should be changed. Once light turns red, it will remain red until function is reset.

#### To Reset Indicator:

- Press and hold both the **Lock** and **Water** buttons simultaneously for *four* seconds. The green filter status indicator light will flash three times when the function has successfully reset.



### Auto Light (select models)



The Auto Light function activates the dispenser light at half-power when the Light Sensor detects that the light levels in room are low.

#### To Activate Auto Light:

- Press **Auto Light** button. A green indicator light above button illuminates when the sensor is active.

#### To Deactivate Auto Light:

- Press **Auto Light** button. The green indicator light will go out.

**Note:** The dispenser light will operate when Auto Light is ON or OFF.

### Sabbath Mode (select models)

When activated, the Sabbath Mode deactivates the control lights while leaving the control operational.

#### To Activate Sabbath Mode:

- Press and hold the **Lock** and **Auto Light** buttons simultaneously for *three to four* seconds. After three to four seconds, the dispenser lights will turn off.



#### To Deactivate Sabbath Mode:

- Press and hold both the **Lock** and **Auto Light** buttons simultaneously for *three to four* seconds. After three to four seconds, the dispenser lights will activate.

#### Notes:

- Dispenser light will not activate during dispensing while in this mode.
- If the power fails, the control will remain in Sabbath Mode when power returns.





# Water Filter

## Water Filter Removal and Installation (select models)

### ⚠ WARNING

To avoid serious illness or death, **do not** use refrigerator where water is unsafe or of unknown quality without adequate disinfection *before* or *after* use of filter.

### ⚠ CAUTION

**After installing a new water filter, always dispense water for two minutes before removing the filter for any reason. Air trapped in system may cause water and cartridge to eject. Use caution when removing.**

- The bypass cap **does not** filter water. Be sure to have replacement cartridge available when filter change is required.
- If water filtration system has been allowed to freeze, replace filter cartridge.
- If system has not been used for several months, or water has an unpleasant taste or odor, flush system by dispensing water for two to three minutes. If unpleasant taste or odor persists, change filter cartridge.

## Initial Installation

The water filter is located in the upper right hand corner of the fresh food compartment.

1. Remove blue bypass cap and retain for later use.
2. Remove sealing label from end of filter and insert into filter head.
3. Rotate gently *clockwise* until filter stops. Snap filter cover closed.
4. Reduce water spurts by flushing air from system. Run water continuously for *two* minutes through dispenser until water runs steady. During initial use of water dispenser, allow up to *one* minute delay while water tank fills before water dispenses.
  - Additional flushing may be required in some households where water is of poor quality.

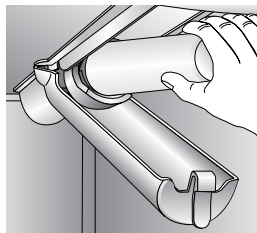
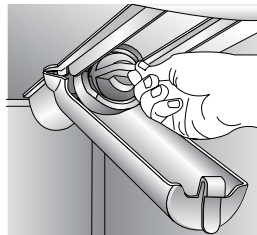

## Replacing Water Filter

**Important:** Air trapped in system may cause water and cartridge to eject. Use caution when removing.

1. Turn filter *counterclockwise* until it releases from filter head.
2. Drain water from filter into sink, and dispose in normal household trash.
3. Wipe up excess water in filter cover and continue with *Initial Installation*, steps 2 and 4.

The filter should be changed at least every 12 months.

**Important:** Condition of water and amount used determines life span of water filter cartridge. If water use is high, or if water is of poor quality, replacement may need to take place more often.

To purchase a replacement water filter cartridge, contact your dealer.

The dispenser feature may be used without a water filter cartridge. If you choose this option, replace filter with blue bypass cap.



# PuriClean II System Specification and Performance Data Sheet

## Refrigerator Water Filter Cartridge

### Specifications

Service Flow Rate (Maximum).....0.78 GPM (2.9 L/min)  
 Rated Service Life 750 (Maximum) .....750 gallons/2838 liters  
 Maximum Operating Temperature.....100° F / 38° C  
 Minimum Pressure Requirement.....35 psi / 241 kPA  
 Minimum Operating Temperature.....33° F / 1° C  
 Maximum Operating Pressure.....120 psi / 827 kPA

### Performance Data

Standard No. 42: Aesthetic Effects								
Parameter	USEPA MCL	Influent Challenge Concentration	Influent Average	Effluent		% Reduction		Min. Required Reduction
				Average	Maximum	Average	Minimum	
Chlorine	–	2.0 mg/L ± 10%	1.88 mg/L	<0.05 mg/L	0.06 mg/L	>97.26%	96.84%	50%
T & O	–	–	–	–	–	–	–	–
Particulate**	–	at least 10,000 particles/ml	5,700,000 #/ml	30,583 #/ml	69,000 #/ml	99.52%	98.94%	85%

Standard No. 53: Health Effects								
Parameter	USEPA MCL	Influent Challenge Concentration	Influent Average	Effluent		% Reduction		Min. Required Reduction
				Average	Maximum	Average	Minimum	
Turbidity	1 NTU**	11 ± 1 NTU***	10.73 NTU	0.36 NTU	.049 NTU	97.09%	95.20%	0.5 NTU
Cysts	99.5% Reduction	Minimum 50,000/L	220,000 #/L	<1	<1	>99.99%	>99.99%	>99.95%
Asbestos	99% Reduction	10 <sup>7</sup> 10 <sup>6</sup> fibers/L; fibers >10 micrometers in length	155 MF/L	<1	<1	>99.99%	>99.99%	99%
Lead at pH 6.5	0.015 mg/L	0.15 mg/L ± 10%	0.153 mg/L	<.001	<.001	>99.35%	>99.35%	0.10 mg/L
Lead at pH 8.5	0.015 mg/L	0.15 mg/L ± 10%	0.150 mg/L	<.001	<.001	>99.35%	>99.35%	0.10 mg/L
Mercury at pH 6.5	0.002 mg/L	.006 mg/L ± 10%	0.006 mg/L	0.00026	0.0005	98.72%	90.91%	0.002 mg/L
Mercury at pH 8.5	0.002 mg/L	.006 mg/L ± 10%	0.006 mg/L	0.0008	0.0015	98.72%	75.93%	0.002 mg/L
Lindane	0.0002 mg/L	0.002 mg/L ± 10%	0.002 mg/L	0.000025	0.00007	98.72%	96.50%	0.0002 mg/L
Toxaphene	0.003 mg/L	0.015 mg/L ± 10%	0.015 mg/L	<0.001	<0.001	92.97%	91.67%	0.003 mg/L
Atrazine	0.003 mg/L	0.009 mg/L ± 10%	.00873 mg/L	<0.002	<0.002	76.99%	75.31%	0.003 mg/L

\* Tested using a flow rate of 0.78 GPM; pressure of 60 psig; pH of 7.5 ± 0.5; temp. of 68° ± 5° F (20° ± 3° C) under standard laboratory conditions, however, actual performance may vary. Health Claim Performance tested and certified by NSF International

\*\* Measurement in Particles /ml. Particles used were 0.5 - 1 microns

\*\*\* NTU - Nephelometric Turbidity units



**Tested and certified by NSF International against ANSI/NSF Standards 42 & 53 in models 750 for the reduction of:**

<b>Standard No. 42: Aesthetic Effects</b> Taste and Odor Reduction Chlorine Taste & Odor Mechanical Filtration Unit Particulate Reduction Class 1	<b>Standard No. 53: Health Effects</b> Chemical Reduction Unit Lead, Atrazine, Lindane, Mercury & Toxaphene Reduction Mechanical Filtration Unit Cyst, Turbidity and Asbestos Reduction
---	---

### General Use Conditions

Read this Performance Data Sheet and compare the capabilities of this unit with your actual water treatment needs.

**DO NOT use this product where water is micro-biologically unsafe or of unknown quality without adequate disinfection before or after the system. System certified for cyst reduction may be used on disinfected water that may contain filterable cysts.**

**USE ONLY WITH COLD WATER SUPPLY. CHECK FOR COMPLIANCE WITH THE STATE AND LOCAL LAWS AND REGULATIONS.**

Timely replacement of filter cartridge is essential for performance satisfaction from this filtration system. Please refer to the applicable section of your Use & Care Guide for general operation, maintenance requirements and troubleshooting.

This system has been tested according to ANSI/NSF 42 and 53 for reduction of the substance listed above. The concentration of the indicated substances in water entering the system was reduced to a concentration less than or equal to the permissible limit for water leaving the system, as specified in ANSI/NSF 42 and 53.



# Food Storage Tips

## Fresh Food Storage

- The fresh food compartment of a refrigerator should be kept between 1°-4° C with an optimum temperature of 3° C. To check the temperature, place an appliance thermometer in a glass of water and place in the center of the refrigerator. Check after 24 hours. If the temperature is above 4° C adjust the controls as explained on pages 7-9.
- Avoid overcrowding the refrigerator shelves. This reduces the circulation of air around the food and results in uneven cooling.

## Fruits and Vegetables

- Storage in the crisper drawers traps humidity to help preserve the fruit and vegetable quality for longer time periods (see page 12).
- Sort fruits and vegetables *before* storage and use bruised or soft items first. Discard those showing signs of decay.
- Always wrap odorous foods such as onions and cabbage so the odor does not transfer to other foods.
- While vegetables need a certain amount of humidity to remain fresh, too much humidity can shorten storage times (especially leafy vegetables). Drain vegetables well *before* storing.
- Wait to wash fresh produce until right before use.

## Meat and Cheese

- Raw meat and poultry should be wrapped securely so leakage and contamination of other foods or surfaces does not occur.
- Occasionally mold will develop on the surface of hard cheeses (Swiss, Cheddar, Parmesan). Cut off at least an inch around and below the moldy area. Keep your knife or instrument out of the mold itself. **Do not** try to save individual cheese slices, soft cheese, cottage cheese, cream, sour cream or yogurt when mold appears.

## Dairy Food

- Most dairy foods such as milk, yogurt, sour cream and cottage cheese have freshness dates on their cartons for appropriate length of storage. Store these foods in the original carton and refrigerate immediately after purchasing and after each use.

## Frozen Food Storage

- The freezer compartment of a refrigerator should be kept at approximately -18° C. To check the temperature, place an appliance thermometer between the frozen packages and check after 24 hours. If the temperature is above -18° C, adjust the control as described on pages 7-9.
- A freezer operates more efficiently when it is at least two-thirds full.

## Packaging Foods for Freezing

- To minimize dehydration and quality deterioration use aluminum foil, freezer wrap, freezer bags or airtight containers. Force as much air out of the packages as possible and be sure they are tightly sealed. Trapped air can cause the food to dry out, change color and develop an off-flavor (freezer burn).
- Overwrap fresh meats and poultry with suitable freezer wrap prior to freezing.
- **Do not** refreeze meat that has completely thawed.

## Loading the Freezer

- Avoid adding too much warm food to the freezer at one time. This overloads the freezer, slows the rate of freezing and can raise the temperature of frozen foods.
- Leave space between the packages so cold air can circulate freely, allowing food to freeze as quickly as possible.
- Avoid storing hard-to-freeze foods such as ice cream and orange juice on the freezer door shelves. These foods are best stored in the freezer interior where the temperature varies less with door openings.



# Care and Cleaning

## ⚠ CAUTION

To avoid personal injury or property damage, observe the following:

- Read and follow manufacturer's directions for all cleaning products.
- **Do not** place buckets, shelves or accessories in dishwasher. Cracking or warping of accessories may result.

## ⚠ WARNING

To avoid electrical shock which can cause severe personal injury or death, disconnect power to refrigerator *before* cleaning. After cleaning, reconnect power.

## Refrigerator Cleaning Chart

PART	DO NOT USE	DO
<b>Smooth or Textured Painted Doors and Exterior (select models)</b> <i>Damage to finish due to improper use of cleaning products or non-recommended products is <b>not</b> covered under this product's warranty.</i>	Abrasive or harsh cleaners Ammonia Chlorine bleach Concentrated detergents or solvents Metal or plastic-textured scouring pads	Use 4 tablespoons of baking soda dissolved in 1 quart (1 liter) warm, soapy water. Rinse surfaces with clean, warm water and dry immediately to avoid water spots.
<b>Cabinet Interior</b>		
<b>Stainless Steel Doors and Exterior (select models)</b> <b>Important:</b> <i>Damage to stainless steel finish due to improper use of cleaning products or non-recommended products is <b>not</b> covered under this product's warranty.</i>	Abrasive or harsh cleaners Ammonia Chlorine bleach Concentrated detergents or solvents Metal or plastic-textured scouring pads Vinegar-based products Citrus-based cleaners	Use warm, soapy water and a soft, clean cloth or sponge. Rinse surfaces with clean, warm water and dry immediately to avoid water spots. To polish and help prevent fingerprints, follow with Stainless Steel Magic Spray (part no. 20000008*).
<b>Door Gaskets</b>	Abrasive or harsh cleaners Metal or plastic-textured scouring pads	Use warm, soapy water and a soft, clean cloth or sponge.
<b>Condenser Coil</b> <i>Remove base grille to access.</i>	Anything other than a vacuum cleaner	Use a vacuum cleaner hose nozzle.
<b>Condenser Fan Outlet Grille</b> <i>See back of refrigerator.</i>		Use a vacuum cleaner hose nozzle with brush attachment.
<b>Accessories</b> <i>Shelves, buckets, drawers, etc.</i>	A dishwasher	Follow removal and installation instructions from appropriate feature section. <b>Allow items to adjust to room temperature.</b> Dilute mild detergent and use a soft, clean cloth or sponge for cleaning. Use a plastic bristle brush to get into crevices. Rinse surfaces with clean, warm water. Dry glass and clear items immediately to avoid spots.



# Care and Cleaning

## Removing Odors From Refrigerator

### ⚠ WARNING

To avoid electrical shock which can cause severe personal injury or death, disconnect power to refrigerator *before* cleaning. After cleaning, reconnect power.

1. Remove all food and turn the refrigerator **OFF**.
2. Disconnect power to the refrigerator.
3. Clean the walls, floor, ceiling of cabinet interior, drawers, shelves and gaskets according to the instructions.
4. Dilute mild detergent and brush solution into crevices using a plastic bristle brush. Let stand for five minutes. Rinse surfaces with warm water. Dry surfaces with a soft, clean cloth.
5. Wash and dry all bottles, containers and jars. Discard spoiled or expired items.
6. Wrap or store odor-causing foods in tightly sealed containers to prevent reoccurring odors.
7. Reconnect power to refrigerator and return food to refrigerator.
8. Allow the refrigerator to cool.
9. After 24 hours, check if odor has been eliminated.

### **If odor is still present:**

1. Remove drawers and place on top shelf of refrigerator.
2. Pack refrigerator and freezer sections – including doors – with crumpled sheets of black and white newspaper.
3. Place charcoal briquettes randomly on crumpled newspaper in both freezer and refrigerator compartments.
4. Close doors and let stand 24 to 48 hours.

## Energy Saving Tips

- Avoid overcrowding refrigerator shelves. This reduces air circulation around food and causes refrigerator to run longer.
- Avoid adding too much warm food to refrigerator at one time. This overloads compartments and slows rate of cooling.
- **Do not** use aluminum foil, wax paper, or paper toweling as shelf liners. This decreases air flow and causes refrigerator to run less efficiently.
- A freezer that is two-thirds full runs most efficiently.
- Locate refrigerator in coolest part of room. Avoid areas of direct sunlight, or near heating ducts, registers or other heat producing appliances. If this is not possible, isolate exterior by using a section of cabinet or an added layer of insulation.
- Clean door gaskets every three months according to cleaning instructions. This will assure that door seals properly and refrigerator runs efficiently.
- Take time to organize items in refrigerator to reduce time that door is open.
- Be sure your doors are closing securely by leveling refrigerator as instructed in your installation instructions.
- Clean condenser coils as indicated in the cleaning instructions every three months. This will increase energy efficiency and cooling performance.



# Care and Cleaning

## Replacing Light Bulbs

### ⚠ WARNING

To avoid electrical shock which can cause severe personal injury or death, disconnect power to refrigerator *before* replacing light bulb. After replacing light bulb, reconnect power.

### ⚠ CAUTION

To avoid personal injury or property damage, observe the following:

- Allow light bulb to cool.
- Wear gloves when replacing light bulb.

## Upper Fresh Food Section

The upper fresh food light bulbs are located behind the front panel. Reach behind the panel to remove the bulbs.

## Lower Fresh Food Section

1. Push up on bottom tabs **(A)** on light cover. Rotate cover up and release tabs **(B)**.
2. Remove light bulb.
3. Replace bulb with appliance bulb **no greater than 40 watts.**
4. Insert top tabs **(B)** of light cover into liner slots and snap bottom tabs **(A)** into liner slots.

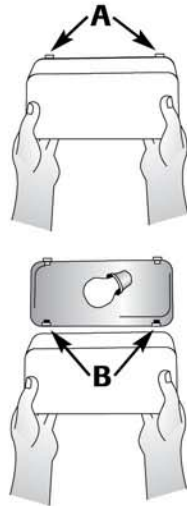

## Upper Freezer Section

1. Remove ice bin by lifting front of bin and pulling out.
2. Remove light shield by pressing the upper right side of the shield and rotating downward.
3. Remove light bulb. Replace with appliance bulb **no greater than 40 watts.**
4. Rotate the shield upward press in slightly and snap into place.
5. Replace ice bin by sliding in until bin locks into place.

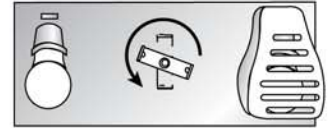

## Lower Freezer Section

1. Pinch both sides of light cover to remove.
2. Remove light bulb. Replace with appliance bulb **no greater than 40 watts.**
3. Pinch both sides of the light cover to snap into place.

## Ice and Water Dispenser (select models)

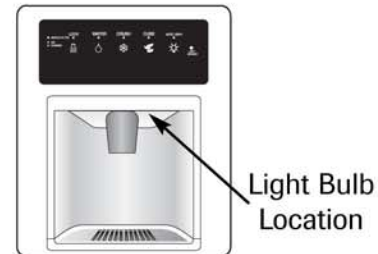

1. Locate light bulb inside top edge of dispenser frame. Unscrew to remove.



# Care and Cleaning

## Preparing for Vacation

### ⚠ CAUTION

If your refrigerator has a dispenser and there is any possibility that the temperature can drop below freezing where the refrigerator is located, the water supply system (including the water tank and the water valve) must be drained by a qualified servicer.

#### For short vacations or absences (three months or less):

1. Remove all perishables.
2. If no one will be checking in on the refrigerator during your absence, remove all frozen items also.
3. If your refrigerator has an automatic ice maker:
  - Shut off the water supply to the ice maker at least one day ahead of time.
  - After the last load of ice drops, raise the wire shut off arm to the **OFF** position.
  - Empty the ice bin.
4. If the room temperature will drop below 13° C, follow the instructions for longer absences.

#### For long vacations, absences (more than three months) OR if the room temperature will drop below 13° C:

1. Remove food.
2. If your refrigerator has an automatic ice maker:
  - Shut off the water supply to the ice maker at least one day ahead of time.
  - After the last load of ice drops, raise the wire shut off arm to the **OFF** position.
  - Empty the ice bin.
3. If your refrigerator has a dispenser system with water filter, remove the water filter cartridge and install the filter bypass. Dispose of the used cartridge.
4. Turn the Freezer control to **OFF**.
5. Unplug the refrigerator.
6. Thoroughly clean the interior of both compartments with a baking soda solution and a clean, soft cloth (four tablespoons of baking soda in one quart of warm water.).
7. Dry thoroughly.
8. Leave the doors open to prevent the formation of mold and mildew.

## Upon Your Return:

### After a Short Vacation or Absence:

For models with automatic ice makers or dispensers:

- Reconnect the water supply and turn on supply valve (see page 3).
- Monitor water connection for 24 hours and correct leaks if necessary.
- Run 10-15 glasses of water from the dispenser to flush out the system.
- Restart the ice maker.
- Discard at least the first *three* ice harvests.

### After a Long Vacation or Absence:

- If your refrigerator has an automatic ice maker, reconnect the water supply and turn on supply valve (see page 3).
- Plug the refrigerator back in and reset controls (see pages 7-9).
- Monitor water connection for 24 hours and correct leaks, if necessary.

For dispenser models, run water through the dispenser for at least *three* minutes with the filter bypass in place, then install water filter (see page 16).

- After installing the water filter, run water through the dispenser continuously for at least *two* minutes, or until water runs steady. Initially you may notice a one to two minute delay in water dispersal as the internal tanks fills.
- Restart the ice maker.
- Discard ice produced within the first 12 hours (at least the first *three* harvests).

## Preparing to Move

- Follow the above instructions for long vacations/absences, through step 7.
- Secure all loose items such as shelves and drawers by taping them securely in place to prevent damage.
- Tape the doors shut.
- Use an appliance dolly when moving the refrigerator. **ALWAYS** truck the refrigerator from its side or back - **NEVER** from its front.
- Be sure the refrigerator stays in an upright position during moving.

# Operating Sounds

Improvements in refrigeration design may produce sounds in your new refrigerator that are different or were not present in an older model. These improvements were made to create a refrigerator that is better at preserving food, is more energy efficient, and is quieter overall. Because new units run quieter, sounds may be detected that were present in older units, but were masked by higher sound levels. Many of these sounds are normal. Please note that the surfaces adjacent to a refrigerator, such as hard walls, floors and cabinetry may make these sounds seem even louder. The following are some of the normal sounds that may be noticed in a new refrigerator.

SOUND	POSSIBLE CAUSE	SOLUTION
<b>Clicking</b>	• Freezer control <b>(A)</b> clicks when starting or stopping compressor.	• Normal operation
	• Defrost timer or electric damper control (select models) <b>(B)</b> sounds like an electric clock and snaps in and out of defrost cycle.	• Normal operation
<b>Air rushing or whirring</b>	• Condenser fan <b>(D)</b> makes this noise while operating.	• Normal operation
	• Freezer fan <b>(C)</b> makes this noise while operating.	• Normal operation
	• Freezer fan <b>(C)</b> slows to a stop as the freezer door is opened.	• Normal operation
<b>Gurgling or boiling sound</b>	• Evaporator <b>(E)</b> and heat exchanger <b>(F)</b> refrigerant make this noise when flowing.	• Normal operation
<b>Thumping</b>	• Ice cubes from ice maker drop into ice bucket <b>(G)</b> .	• Normal operation
	• Dispenser ice chute <b>(H)</b> closing.	• Normal operation
<b>Vibrating noise</b>	• Compressor <b>(I)</b> makes a pulsating sound while running.	• Normal operation
	• Refrigerator is not level.	• See <i>Leveling</i> , see page 6.
<b>Buzzing</b>	• Ice maker water valve <b>(J)</b> hookup buzzes when ice maker fills with water.	• Normal operation
<b>Humming</b>	• Ice maker <b>(K)</b> is in the 'on' position without water connection.	• Normal operation
	• Ice auger <b>(L)</b> hums as auger agitates ice during dispensing.	• Normal operation
	• Compressor <b>(I)</b> can make a high-pitched hum while operating.	• Normal operation
	• Solenoid valve <b>(M)</b> operating ice chute door.	• Normal operation

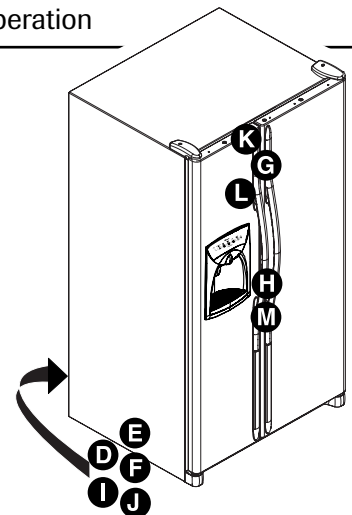
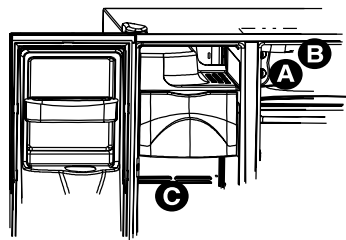



# Troubleshooting

PROBLEM	POSSIBLE CAUSES	WHAT TO DO	
<b>Freezer control and lights are on, but compressor is not operating</b>	Refrigerator is in defrost mode.	Normal operation. Wait 40 minutes to see if refrigerator restarts.	
<b>Temperature-controlled drawers are too warm</b>	Control settings are too low.	See page 12 to adjust controls.	
	Freezer controls are set too low.	See pages 7-9 to adjust controls.	
	Drawer is improperly positioned.	See page 12 to verify drawer positioning.	
<b>Refrigerator does not operate</b>	Refrigerator is not plugged in.	Plug in refrigerator.	
	Dial control in freezer is set to OFF (select models).	See pages 7-9 to adjust controls.	
	Touch temperature controls are set to “-” (select models).	See pages 7-9 to adjust controls.	
	Fuse is blown, or circuit breaker needs to be reset.	Replace any blown fuses. Check circuit breaker and reset, if necessary.	
	Power outage has occurred.	Call local power company listing to report outage.	
<b>Refrigerator still won't operate</b>	Refrigerator is malfunctioning.	Unplug refrigerator and transfer food to another refrigerator. If another refrigerator is not available, place dry ice in freezer section to preserve food. Warranty does not cover food loss. Contact service for assistance.	
<b>Food temperature is too cold</b>	Condenser coils are dirty.	Clean according to the chart on page 19.	
	Refrigerator or freezer controls are set too high.	See pages 7-9 to adjust controls.	
<b>Food temperature is too warm</b>	Door is not closing properly.	Refrigerator is not level. See page 6 for details on how to level your refrigerator. Check gaskets for proper seal. Clean, if necessary, according to the chart on page 19. Check for internal obstructions that are keeping door from closing properly (i.e. improperly closed drawers, ice buckets, oversized or improperly stored containers, etc.)	
	Controls need to be adjusted.	See pages 7-9 to adjust controls.	
	Condenser coils are dirty.	Clean according to the chart on page 19.	
	Rear air grille is blocked.	Check the positioning of food items in refrigerator to make sure grille is not blocked. Rear air grilles are located under crisper drawers.	
	Door has been opened frequently, or has been opened for long periods of time.	Reduce time door is open. Organize food items efficiently to assure door is open for as short a time as possible.	
	Food has recently been added.	Allow time for recently added food to reach refrigerator or freezer temperature.	
	<b>Refrigerator has an odor</b>	Odor producing foods should be covered or wrapped.	Clean according to instructions on page 19.
		The interior needs cleaning.	

Cont.

# Troubleshooting

PROBLEM	POSSIBLE CAUSES	WHAT TO DO
<b>Water droplets form on outside of refrigerator</b>	Door is not closing properly.	Check for internal obstructions that are keeping door from closing properly (i.e. improperly closed drawers, ice buckets, oversized or improperly stored containers, etc.) See page 6 <i>Leveling</i> .
	Door gaskets are not sealing properly.	Clean according to the chart on page 19.
	Humidity levels are high.	Normal during times of high humidity.
	Controls require adjustment.	See pages 7-9 to adjust controls.
<b>Water droplets form on inside of refrigerator</b>	Humidity levels are high or door has been opened frequently.	Reduce time door is open. Organize food items efficiently to assure door is open for as short a time as possible.
	Door gaskets are not sealing properly.	Clean according to the chart on page 19.
<b>Refrigerator or ice maker makes unfamiliar sounds or seems too loud</b>	Normal operation.	See page 23.
<b>Temperature-controlled drawer and/or crisper drawer do not close freely</b>	Contents of drawer, or positioning of items in the surrounding compartment could be obstructing drawer.	Reposition food items and containers to avoid interference with the drawers.
	Drawer is not in proper position.	See page 12 for proper drawer placement.
	Refrigerator is not level.	See page 6 for details on how to level your refrigerator.
	Drawer channels are dirty.	Clean drawer channels with warm, soapy water. Rinse and dry thoroughly. Apply a thin layer of petroleum jelly to drawer channels.
<b>Refrigerator runs too frequently</b>	Doors have been opened frequently or for long periods of time.	Reduce time door is open. Organize food items efficiently to assure door is open for as short a time as possible. Allow interior environment to adjust for period the door has been opened.
	Humidity or temperature in surrounding area is high.	Normal operation.
	Food has recently been added.	Allow time for recently added food to reach refrigerator or freezer temperature.
	Refrigerator is exposed to heat by environment or by appliances nearby.	Evaluate your refrigerator's environment. Refrigerator may need to be moved to run more efficiently.
	Condenser coils are dirty.	Clean according to the chart on page 19.
	Controls need to be adjusted.	See pages 7-9 to adjust controls.
	Door is not closing properly.	Refrigerator is not level, see page 6 <i>Leveling</i> . Check for internal obstructions that are keeping door from closing properly (i.e. improperly closed drawers, ice buckets, oversized or improperly stored containers, etc.)
	Door gaskets are not sealing properly.	Cleaning according to the chart on page 19.

# Troubleshooting

## Ice and Water

PROBLEM	POSSIBLE CAUSES	WHAT TO DO
<b>No indicator lights are lit on dispenser control</b>	Freezer door is not closed.	Verify that freezer door is closed. Power is removed from the control when freezer door is opened.
	Refrigerator is not plugged in.	Plug in refrigerator.
	Fuse is blown, or circuit breaker needs to be reset.	Replace any blown fuses. Check circuit breakers for any tripped circuits.
	Power outage has occurred.	Call local power company listing to report outage.
	Refrigerator is in Sabbath Mode.	See <i>Sabbath Mode</i> , page 15.
<b>Ice or water are not dispensed when pads are pressed</b>	Freezer door is not closed.	Verify that freezer door is closed. Power is removed from the control when freezer door is opened.
	Controls are in lock mode (select models).	See <i>Dispenser Lock</i> , page 15.
	Water tank is filling.	At initial use, there is an approximate one- to two-minute delay in dispensing while the internal water tank is filling.
	Ice maker has just been installed or a large amount of ice has been used.	Wait 24 hours for ice production to begin or for ice maker to restock after emptied.
	Water filter is clogged or needs to be changed.	Change water filter (see page 16).
<b>Ice maker is not producing enough ice or ice is malformed</b>	Ice maker has just been installed or a large amount of ice has been used.	Wait 24 hours for ice production to begin or for ice maker to restock after emptied.
	Water pressure is too low.	Low water pressure can cause valve to leak. Water pressure must be between 241 to 689 KPA to function properly. A minimum pressure of 241 KPA is recommended for refrigerators with water filters.
	Water filter is clogged or needs to be changed.	Change water filter (see page 16).
<b>Ice maker is not producing ice</b>	Ice maker arm is up.	Confirm ice maker arm is down. See <i>Automatic Ice Maker</i> , page 14.
	Household water supply is not reaching water valve.	See <i>Connecting the Water Supply</i> , page 3.
	Supply tubing has kinks.	Turn off water supply and remove kinks. If kinks cannot be removed, replace tubing.
	Water pressure is too low.	Water pressure must be between 241 to 689 KPA to function properly. A minimum pressure of 241 KPA is recommended for refrigerators with water filters.
	Check freezer temperature.	See <i>Temperature Controls</i> , pages 7-9 to adjust controls. Freezer must be between -18° to -17° C to produce ice.
	Ice bin is not installed properly.	See <i>Ice Storage Bin</i> , page 13.
	Improper water valve was installed.	See <i>Connecting the Water Supply</i> , page 3. Self-piercing and 3/16" saddle valves cause low water pressure and may clog the line over time. <b>The manufacturer is not responsible for property damage due to improper installation or water connection.</b>
<b>Water filter indicator light is red</b>	Water filter needs to be replaced.	If filter is not available, replace with bypass filter. See <i>Water Filter</i> , page 16.
	Filter indicator sensor needs to be reset.	See <i>Filter Status Indicator Light</i> , page 15.

Cont.



# Troubleshooting

PROBLEM	POSSIBLE CAUSES	WHAT TO DO
<b>Ice forms in inlet tube to ice maker</b>	Water pressure is low.	Water pressure must be between 241 to 689 kpa to function properly. A minimum pressure of 241 kpa is recommended for refrigerators with water filters.
	Saddle valve not open completely.	Open saddle valve completely.
	Freezer temperature is too high.	See <i>Temperature Controls</i> , pages 7-9. Freezer temperature should be between -18° to -17° C.
<b>Refrigerator is leaking water</b>	Supply tubing was used to complete water connection.	The manufacturer recommends using copper tubing for installation. Plastic is less durable and can cause leakage. <b>The manufacturer is not responsible for property damage due to improper installation or water connection.</b>
	Improper water valve was installed.	See <i>Connecting the Water Supply</i> page 3. Self-piercing and 3/16" saddle valves cause low water pressure and may clog the line over time. <b>The manufacturer is not responsible for property damage due to improper installation or water connection.</b>
<b>Water flow is slower than normal</b>	Water pressure is low.	Water pressure must be between 241 to 689 kpa to function properly. A minimum pressure of 241 kpa is recommended for refrigerators with water filters.
	Saddle valve not open completely.	Open saddle valve completely.
	Improper water valve was installed.	See <i>Connecting the Water Supply</i> , page 3. Self-piercing and 3/16" saddle valves cause low water pressure and may clog the line over time. <b>The manufacturer is not responsible for property damage due to improper installation or water connection.</b>
	Supply tubing has kinks.	Turn off water supply and remove kinks. If kinks cannot be removed, replace tubing.
	Water filter is clogged or needs to be changed.	Change water filter (see page 16).
	Water valve not opened completely.	Open water valve completely and check for leaks. The minimum flow at dispenser is approximately 295 ml in nine seconds with a new filter in place or approximately 295 ml in five seconds without a filter.
<b>Dispenser water is not cold</b>	Refrigerator has been recently installed.	Allow approximately 12 hours for water in holding tank to chill.
	Water supply in holding tank has been depleted.	
	Water has settled into water lines outside holding tank and has warmed to room temperature.	Discard first glass of water and refill.
<b>Water appears cloudy</b>	Air or air bubbles in water.	This is normal when first using the dispenser and will disappear with use.
<b>Particles in water and/or ice cubes.</b>	Carbon dust from water filter cartridge.	Initial water ejected through cartridge may contain harmless carbon dust flushed from cartridge. Particles are safe for consumption. Will disappear after the first few uses.
	Concentrations of minerals in water will form particles when water becomes frozen and melts.	Particles are not harmful and naturally occur in water supplies.