

# BEDIENUNGS- UND MONTAGEANWEISUNG

EN User Manual

## EMWG6260

---

**Küppersbusch**

FÜR KÜCHEN MIT STIL

Safety Information .....	29
Safety Instructions .....	32
The advantages of microwaves .....	33
Description of microwave oven .....	34
Basic settings .....	36
Basic functions .....	37
When the oven is working... ..	39
Defrosting .....	40
Cooking with a microwave oven .....	42
Cooking with the grill .....	44
What kind of ovenware can be used? .....	46
Oven Cleaning and Maintenance.....	48
What should I do if the oven doesn't work? .....	50
Technical characteristics.....	51
Environmental protection .....	51
Installation instructions.....	52
Installation .....	53

Dear Customer:

Thank you for choosing this **Küppersbusch** product.

We ask you to read the instructions in this booklet very carefully as this will allow you to get the best results from using it.

KEEP THE DOCUMENTATION OF THIS PRODUCT FOR FUTURE REFERENCE.

**Always keep the instruction manual handy. If you lend the Steam oven to someone else give them the manual as well!**

The user manual is also available for download at [www.kueppersbusch.de](http://www.kueppersbusch.de).

## Safety Information



Before the installation and use of the appliance, carefully read the supplied instructions. The manufacturer is not responsible if an incorrect installation and use causes injuries and damages. Always keep the instructions with the appliance for future reference.

### CHILDREN AND VULNERABLE PEOPLE SAFETY

#### **Warning! Risk of suffocation, injury or permanent disability.**

- This appliance can be used by children aged from 8 years and above and persons with reduced physical, sensory or mental capabilities or lack of experience and knowledge if they are supervised by an adult or a person who is responsible for their safety.
- Do not let children play with the appliance.
- Keep all packaging away from children.
- **WARNING:** Keep children away from the appliance when it operates or when it cools down. Accessible parts are hot.
- If the appliance has a child safety device, we recommend that you activate it. Children under 3 years must not be left unsupervised in the vicinity of the appliance.
- Cleaning and user maintenance shall not be made by children without supervision.

### GENERAL SAFETY

- This appliance is intended to be used in household and similar applications such as:
  - staff kitchen areas in shops, offices and other working environments;
  - farm houses;
  - by clients in hotels, motels and other residential environments;
  - bed and breakfast type environments.
- Internally the appliance becomes hot when in operation. Do not touch the heating elements that are in the appliance. Always use oven gloves to remove or put in accessories or ovenware.

**WARNING:** Do not heat liquids and other foods in sealed containers. They are liable to explode.

- Only use utensils that are suitable for use in microwave ovens.
- When heating food in plastic or paper containers, keep an eye on the appliance due to the possibility of ignition.

The appliance is intended for heating food and beverages. Drying of food or clothing and heating of warming pads, slippers, sponges, damp cloth and similar may lead to risk of injury, ignition or fire.

- **Warning!** The oven cannot be used if:
  - The door is not closed correctly;
  - The door hinges are damaged;
  - The surfaces of the contact between the door and the oven front are damaged;
  - The door window glass is damaged;
  - There is frequent electrical arcing inside the oven even though there is no metal object inside.

The oven can only be used again after it has been repaired by a Technical Assistance Service technician.

- If smoke is emitted, switch off or unplug the appliance and keep the door closed in order to stifle any flames.
- Microwave heating of beverages can result in delayed eruptive boiling. Care must be taken when handling the container.
- The contents of feeding bottles and baby food jars shall be stirred or shaken and the temperature checked before consumption, in order to avoid burns.
- Eggs in their shell and whole hard-boiled eggs should not be heated in the appliance since they may explode, even after microwave heating has ended.

## **INSTALLATION**

- The electrical installation is to be set up so that the appliance can be isolated from the mains with a minimum 3mm all-pole contact separation.
- Suitable separation devices include e.g. cutouts, fuses (screw fuses are to be taken out of the holder), RCD's and contactors. This installation must comply with current regulations.
- If the electrical connection is done through a plug and this remains accessible after installation, then it is not necessary to provide the mentioned separation device.
- Protection against electric shock must be provided by the electrical installation
- Warning: The oven must be earthed.

## **CLEANING**

- The appliance should be cleaned regularly and any food deposits removed.
- Failure to maintain the appliance in a clean condition could lead to deterioration of the surface that could adversely affect the life of the appliance and possibly result in a hazardous situation.

## Safety Information

- Do not use harsh abrasive cleaners or sharp metal scrapers to clean the glass door since they can scratch the surface, which may result in shattering of the glass.
- Do not use a steam cleaner to clean the appliance.
- The door contact surfaces (the front of the cavity and the inside part of the doors) must be kept very clean in order to ensure the oven functions correctly.
- Please follow the instructions regarding cleaning in the section "Oven Cleaning and Maintenance".

## REPAIRS

- **WARNING:** Before maintenance cut the power supply.
- **WARNING:** Only a competent person can carry out any service or repair operation that involves the removal of a cover which gives protection against exposure to microwave energy.
- **WARNING:** If the door or door seals are damaged, the appliance must not be operated until it has been repaired by a competent person.
- If the power cable is damaged it should be substituted by the manufacturer, authorized agents or technicians qualified for this task in order to avoid dangerous situations. Furthermore, special tools are required for this task.
- Repair and maintenance work, especially of current carrying parts, can only be carried out by technicians authorized by the manufacturer.

## Safety Instructions

- **Warning!** Do not heat pure alcohol or alcoholic drinks in the microwave. **FIRE RISK!**
- **Beware!**
- To avoid food overheating or burning it is very important not to select long time periods or power levels that are too high when heating small quantities of food. For example, a bread roll can burn after 3 minutes if the power selected is too high.
- For toasting, use just the grilling function and watch the oven all the time. If you use a combined function to toast bread it will catch fire in a very short time.
- Make sure you never catch the power cables of other electrical appliances in the hot door or the oven. The cable insulation may melt.
- **Danger of short-circuiting!**

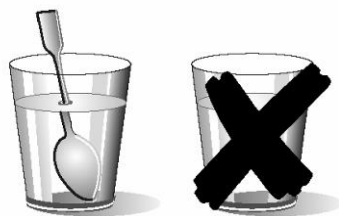

- **Take care when heating liquids!**
- When liquids (water, coffee, tea, milk, etc.) are nearly at boiling point inside the oven and are taken out suddenly, they may spurt out of their containers.
- **DANGER OF INJURIES AND BURNS!**
- To avoid that type of situation when heating liquids, put a teaspoon or glass rod inside the container.
- **Avoid damaging the oven or other dangerous situations by following these instructions:**

- Do not switch on the oven without the turntable support, the turntable ring and the respective plate being in place.
- Never switch on the microwave when it is empty. If there is no food inside there may be an electrical overcharge and the oven could be damaged.  
**RISK OF DAMAGE!**
- For carrying out oven programming tests put a glass of water inside the oven. The water will absorb the microwaves and the oven will not be damaged.
- Do not cover or obstruct the ventilation openings.
- Use only dishes suitable for microwaves. Before using dishes and containers in the microwave, check that these are suitable (see the section on types of dishes).
- Never remove the mica cover on the ceiling of the oven interior! This cover stops fat and pieces of food damaging the microwave generator.
- Do not keep any inflammable object inside the oven as it may burn if the oven is switched on.
- Do not use the oven as a pantry.
- Do not use the oven for frying as it is impossible to control the temperature of oil heated by microwaves.
- Do not lean or sit on the open oven door. This may damage the oven, especially in the hinge zone. The door can bear a maximum weight of 8 kg. The turntable and the grills can bear a maximum load of 8 kg. To avoid damaging the oven, do not exceed this load.

## The advantages of microwaves

In conventional ovens, heat radiated by electrical elements or gas burners slowly penetrates the food from outside to inside. On account of this there is a major amount of energy is wasted heating the air, the oven components and the food containers.

In a microwave oven, heat is generated by the food itself and the heat travels from inside to outside. No heat is lost to the air, the walls of the oven cavity or the dishes and containers (if these are suitable for use in microwave oven), in other words, only the food is heated.

Microwave ovens have the following advantages:

1. Shorter cooking times; in general these are up to 3/4 less than the time required for conventional cooking.
2. Ultra-fast food defrosting, thus reducing the danger of bacterial development.
3. Energy savings.
4. Conservation of the nutritional value of foods due to the shorter cooking times.
5. Easy to clean.

### How a microwave oven works

In a microwave oven there is a high tension valve called a magnetron which converts electrical energy into microwave energy. These electromagnetic waves are channelled to the interior of the oven through a wave guide and distributed by a metallic spreader or through a turntable.

Inside the oven the microwaves propagate in all directions and are reflected by the metal walls, uniformly penetrating the food.

### Why food heats up

Most foods contain water and water molecules vibrate when subjected to microwaves.

The friction between molecules produces heat which raises the temperature of the food, de-freezing it, cooking it or keeping it hot.

Since the heat arises inside the food:

- This can be cooked with little or no liquid or fats/oils;
- De-freezing, heating or cooking in a microwave oven is quicker than in a conventional oven;
- The vitamins, minerals and nutritional substances in the food are conserved;
- The natural colour and aroma of the food are unchanged.

Microwaves pass through china, glass, cardboard or plastic but do not go through metal. For this reason, metal containers or ones with metal parts must not be used in a microwave oven.

Microwaves are reflected by metal...

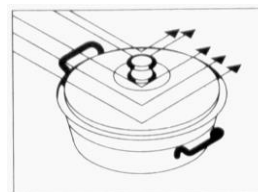

... but go through glass and china...

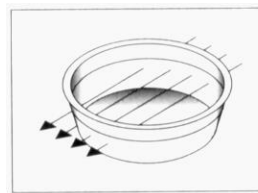

and are absorbed by foods.

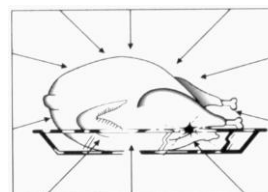

# Description of microwave oven

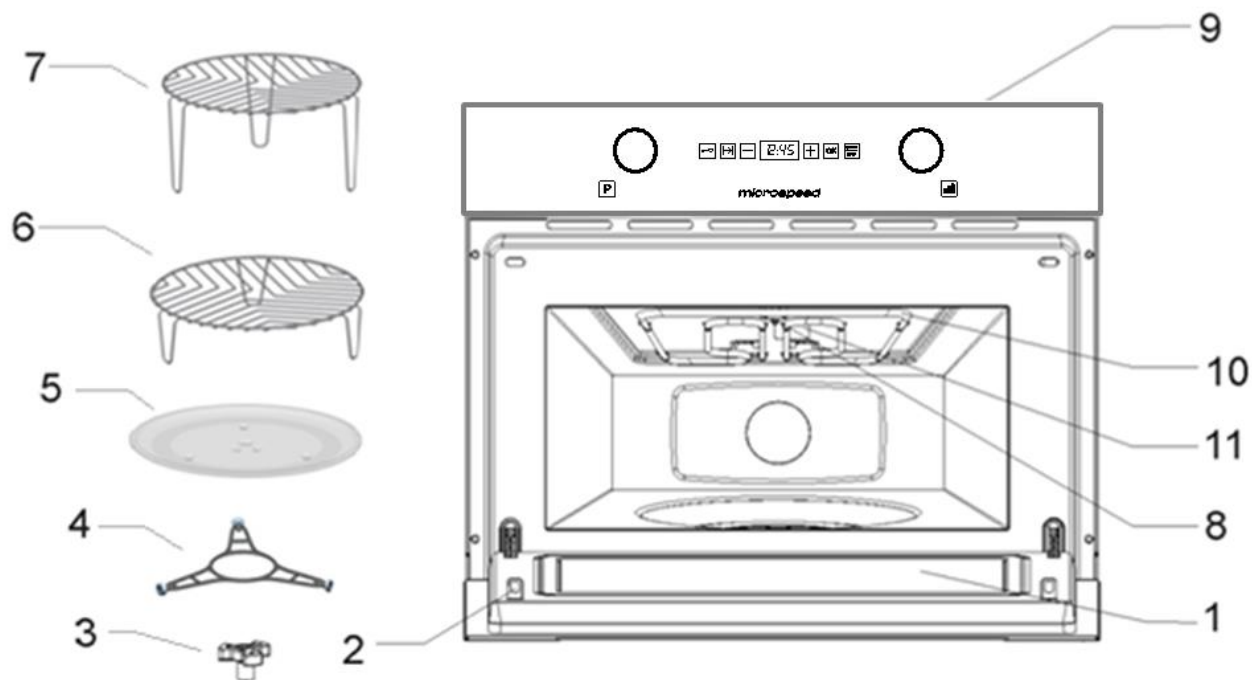

- 1. – Door window glass
- 2. – Catches
- 3. – Turntable support
- 4. – Turntable ring
- 5. – Turntable plate
- 6. – Low grille
- 7. – High grille
- 8. – Lamp
- 9. – Control panel
- 10. – Grill
- 11. – Mica cover

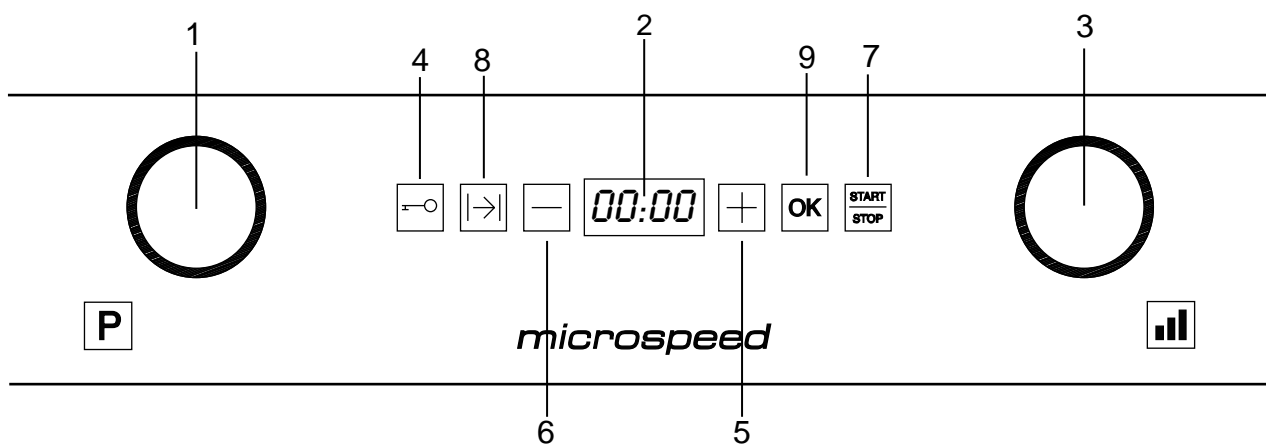













- 1. – Function Selector
- 2. – Display
- 3. – Microwave power selector
- 4. – Child lock key
- 5. – “+” Key
- 6. – “-” Key
- 7. – Start/Stop key
- 8. – Duration key
- 9. – Confirmation key



## Description of microwave oven

### Description of Functions

Function	Microwaves Power	Foods
	 180 W	Slow defrosting for delicate foods; keeping food hot
	 300 W	Cooking with little heat; boiling rice. Rapid defrosting
	 550 W	Melting butter. Heating baby food
	 750 W	Cooking vegetables and food. Cooking and heating carefully. Heating and cooking small portions of food. Heating delicate food
	 1000 W	Cooking and rapidly heating liquids and pre-cooked foods
	 150 W	Toasting food
	 300 W	Grilling poultry and meat
	 550 W	Cooking pies and cheese-topped dishes
	 750 W	Use carefully: food might burn.
	 1000 W	Use carefully: food might burn.
	---	Grilling food

## Setting the clock

After your microwave oven is first plugged-in or after a power failure, the clock display will flash to indicate that the time shown is not correct.

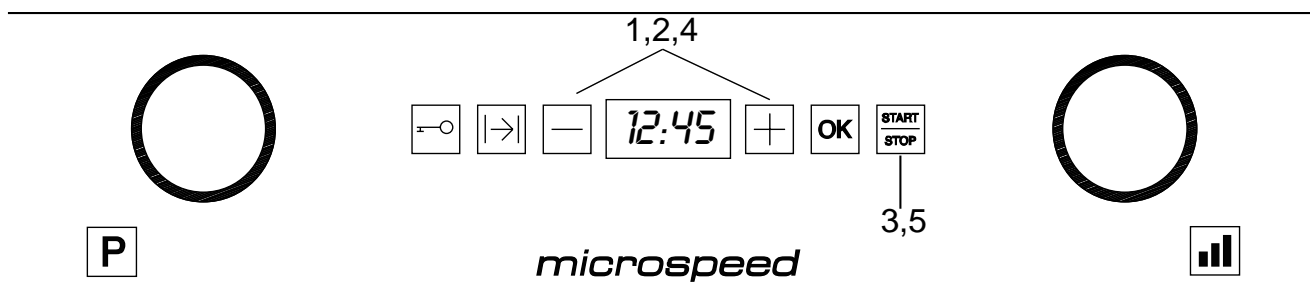

1. Press the "+" and "-" keys until the **current time** display flashes. Press the **start key** until the hour flashes (not necessary when you have just plugged it in or after a power cut).
2. Press the "+" or "-" keys until the hour flashes. (Key the hour symbol until it flashes.)
3. Press the **start key** to confirm the hour set.
4. To set the minutes, press the "+" or "-" keys until the minute flashes.
5. Press the **start key** to confirm the minute.

## Hiding/Displaying the Clock

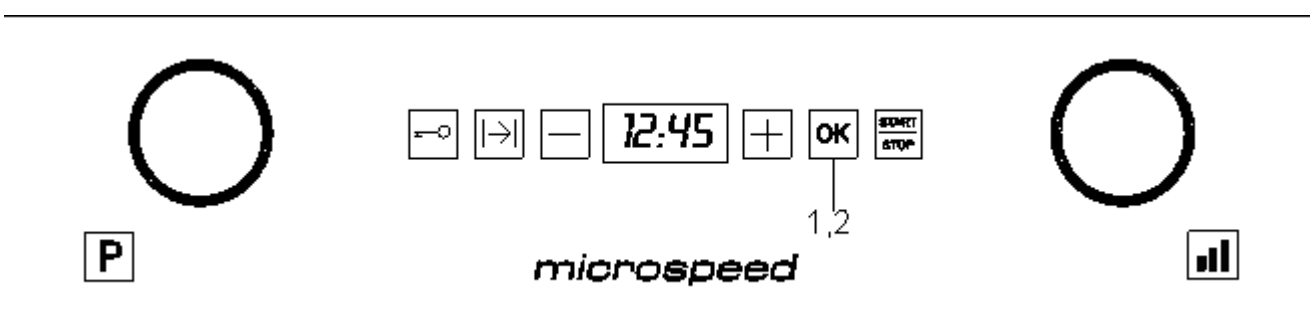

1. - You can hide the clock by pressing the OK key for 3 seconds.
2. - If you want to see the clock display again, press the OK key again for 3 seconds.

## Basic Settings

### Child Lock function

The Oven function can be blocked (for example, to stop it being used by children).

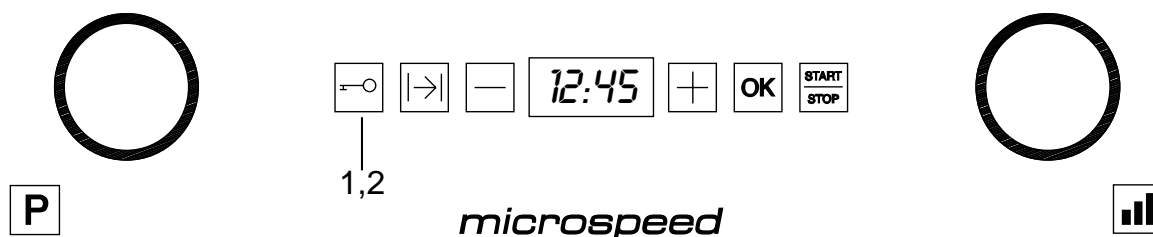



1. To block the oven, press the Child lock key for 3 seconds. You will hear a sound signal and the display will show the word "SAFE". The oven is blocked in this state and cannot be used.

2. To unblock the oven, press the **STOP** key again for 3 seconds. You will hear a sound signal and the **display** will show the time again.

### Microwave

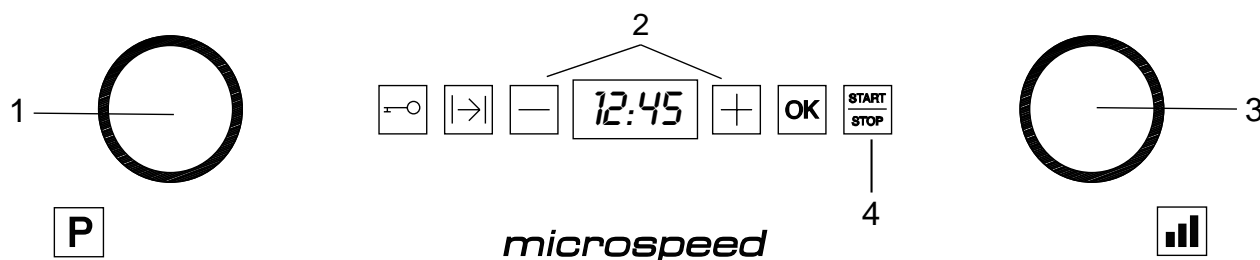
Use this function to cook and heat up vegetables, potatoes, rice, fish and meat.



1. Turn the **function selector** to the microwave position . The duration icon  and the numbers begin to flash.

2. With the "+" and "-" keys, select the **duration**.



3. Spin the power selector of the microwave in the wanted position (see technical characteristics).

4. Press the **Start/Stop key**. The Oven will start to operate.

## Grill

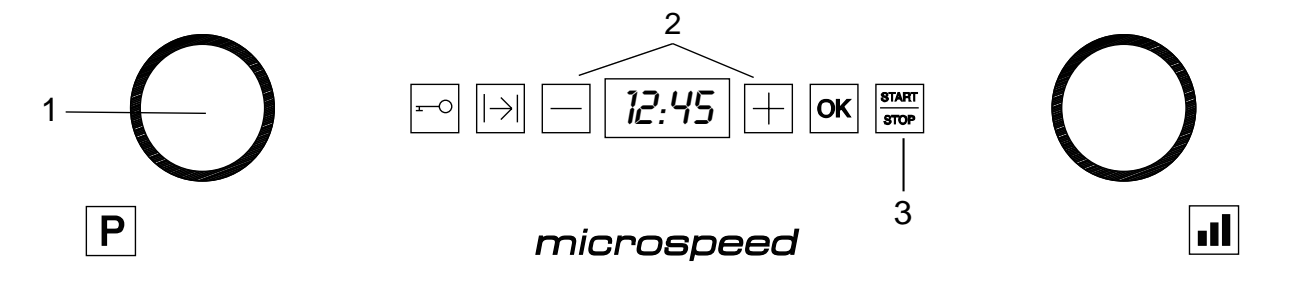
Use this function to brown the surface of food quickly.



1. Turn the **function selector** to the **grill** position. .  
The duration icon  and the numbers begin to flash.
2. The numbers will flash. With the “+” and “-“keys, set the desired time.



3. Press the **Start/Stop key**. The cooking process will begin.

Please note: The position of the microwave selector does **not** affect the operation.

## Microwave + Grill

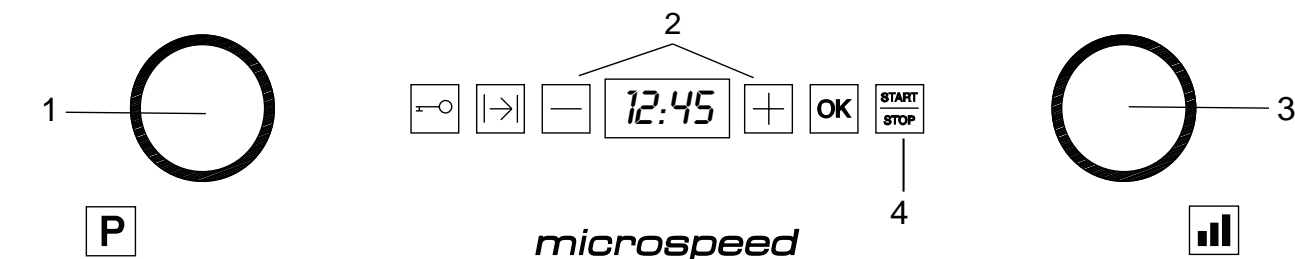
Use this function to cook lasagne, poultry, baked potatoes and casseroles.



1. Turn the **function selector** to the microwave + Grill position . The duration icon  and the numbers begin to flash.
2. With the “+” and “-“keys, select the **duration**.

3. Spin the power selector of the microwave in the wanted position (see technical characteristics).
4. Press the **Start/Stop key**. The Oven will start to operate.

## When the oven is working...

### Interrupting a cooking cycle

You can stop the cooking process at any time by pressing the **Stop** key once or by opening the oven door.

In both cases:

- **Microwave emission is stopped immediately.**
- The grill is de-activated but is **still very hot. Danger of burning!**
- The timer stops automatically, indicating the operating time that is left.

If you wish, at this time you can:

1. Turn or stir the food to ensure it will be evenly cooked.
2. Change the process parameters.

To restart the process, close the door and press the **Start/Stop** key.

### Altering parameters

The operating parameters

- Time (with the “+” and “-” keys)
- Function (with the function selector)
- Power (with the microwave power level selector)

can be altered when the oven is operating or when the cooking process has been interrupted by simply turning the respective knob to the new value.

### Cancelling a cooking cycle



If you wish to cancel the cooking process, press the **Start/Stop** key twice.

### End of a cooking cycle

At the end of the process you will hear three beeps and the display will show the word “**End**”.

# Defrosting

To defrost food you should select Microwave function with one of the following Power Levels:

Position	Power Level	Power
	Defrost / Keep Warm	150 W
	Defrost	300 W

The table below shows different defrosting and standing times (in order to ensure the food temperature is evenly distributed) for different types and weights of food, plus recommendations.

Food	Weight (g)	Defrosting time (min)	Standing time (min)	Recommendation
Portions of meat, veal, beef, pork	100	2-3	5-10	Turn once
	200	4-5	5-10	Turn once
	500	10-12	10-15	Turn twice
	1000	21-23	20-30	Turn twice
	1500	32-34	20-30	Turn twice
	2000	43-45	25-35	Turn three times
Goulash	500	8-10	10-15	Turn twice
	1000	17-19	20-30	Turn three times
Minced meat	100	2-4	10-15	Turn twice
	500	10-14	20-30	Turn three times
Sausages	200	4-6	10-15	Turn once
	500	9-12	15-20	Turn twice
Poultry (portions)	250	5-6	5-10	Turn once
Chicken	1000	20-24	20-30	Turn twice
Poularde	2500	38-42	25-35	Turn three times
Fish fillet	200	4-5	5-10	Turn once
Trout	250	5-6	5-10	Turn once
Prawns	100	2-3	5-10	Turn once
	500	8-11	15-20	Turn twice
Fruit	200	4-5	5-10	Turn once
	300	8-9	5-10	Turn once
	500	11-14	10-20	Turn twice
Bread	200	4-5	5-10	Turn once
	500	10-12	10-15	Turn once
	800	15-17	10-20	Turn twice
Butter	250	8-10	10-15	
Cream cheese	250	6-8	10-15	
Creams	250	7-8	10-15	

# Defrosting

## General instructions for defrosting

1. When defrosting, use only dishes that are appropriate for microwaves (china, glass, suitable plastic).
2. The defrost function by weight and the tables refer to the defrosting of raw food.
3. The defrosting time depends on the quantity and thickness of the food. When freezing food keep the defrosting process in mind. Distribute the food evenly in the container.
4. Distribute the food as best as possible inside the oven. The thickest parts of fish or chicken drumsticks should be turned towards the outside. You can protect the most delicate parts of food with pieces of aluminium foil. **Important:** The aluminium foil must not come into contact with the oven cavity interior as this can cause electrical arcing.
5. Thick portions of food should be turned several times.
6. Distribute the frozen food as evenly as possible since narrow and thin portions defrost more quickly than the thicker and broader parts.
7. Fat-rich foods such as butter, cream cheese and cream should not be completely defrosted. If they are kept at room temperature they will be ready to be served in a few minutes. Frozen cream must be stirred prior to use.
8. Place poultry on an upturned plate so that the meat juices can run off more easily.
9. Bread should be wrapped in a napkin so that it does not become too dry.
10. Remove frozen food from its wrapping and do not forget to take off any metal twist-tags. For containers that are used to keep frozen food in the freezer and which can also be used for heating and cooking, all you need to do is take off the lid. For all other cases you should put the food into containers that are suitable for microwave use.
11. The liquid resulting from defrosting, principally that from poultry should be discarded. In no event should such liquids be allowed to come into contact with other foods.
12. Do not forget that by using the defrosting function you need to allow for standing time until the food is completely defrosted.

## Cooking with a microwave oven

**Warning! Read the section “Microwave Safety” before cooking with your microwave.**

Follow these recommendations when cooking with your microwave:

- Before heating or cooking foods with peel or **skin** (e.g. apples, tomatoes, potatoes, sausages) **prick them** so that they do not burst. Cut the food up before starting to prepare it.
- Before using a container or dish make sure that it is suitable for microwave use (see the section on types of ovenware).
- When cooking food with very little moisture (e.g. **defrosting bread**, making popcorn, etc.) evaporation is very quick. The oven then works as if it was empty and the food may burn. The oven and the container may be damaged in such a situation. You should therefore set just the cooking time necessary and you must keep a close eye on the cooking process.
- It is not possible to heat large quantities of oil (**frying**) in the microwave.
- Remove **pre-cooked food** from the containers they come in since these are not always heat resistant. Follow the food manufacturer's instructions.
- **If you have several containers**, such as cups, for example, set them out uniformly on the turntable plate.
- Do not close **plastic bags** with metal clips. Use plastic clips instead. Prick the bags several times so that the steam can escape easily.
- When heating or cooking foods, check that they reach **at least a temperature of 70°C**.
- During cooking, **steam** may form on the oven door window and may start to drip. This situation is normal and may be more noticeable if the room temperature is low. The oven's safe working is not affected by this. After you have finished cooking, clean up the water coming from the condensation

- When heating liquids, use **containers with a wide opening**, so that the steam can evaporate easily.

Prepare the foods as per the instructions and keep in mind the cooking times and power levels indicated in the tables.

Keep in mind that the figures given are only indicative and can vary depending on the initial state, temperature, moisture and type of food. It is advisable to adjust the times and power levels to each situation. Depending on the exact characteristics of the food you may need to increase or shorten the cooking times or increase or decrease the power levels.

### Cooling with microwaves...

1. The greater the amount of food, the longer the cooking time. Keep in mind that:
  - Double the quantity » double the time
  - Half the quantity » half the time
2. The lower the temperature, the longer the cooking time.
3. Foods containing a lot of liquid heat up more quickly.
4. Cooking will be more uniform if the food is evenly distributed on the turntable. If you put dense foods on the outside part of the plate and less dense ones on the centre of the plate, you can heat up different types of food simultaneously.
5. You can open the oven door at any time. When you do this the oven switches off automatically. The microwave will only start working again when you close the door and press the start key.
6. Foods that are covered require less cooking time and retain their characteristics better. The lids used must let microwaves pass through and have small holes that allow steam to escape.



## Cooking with a microwave oven

### Tables and suggestions – Cooking vegetables

Food	Quantity (g)	Addition of liquids	Power (Watt)	Time (min.)	Standing Time (min.)	Instructions
Cauliflower	500	100 ml	750	9-11	2-3	Divide into florets
Broccoli	300	50 ml	750	6-8	2-3	Cut into slices
Mushrooms	250	25 ml	750	6-8	2-3	Turn 1 x, cover
Peas & carrots,	300	100 ml	750	7-9	2-3	Cut into cubes or slices. Cover. Turn 1 x
Frozen carrots	250	25 ml	750	8-10	2-3	
Potatoes	250	25 ml	750	5-7	2-3	Peel, cut into uniform pieces. Cover, turn 1 x
Pepper	250	25 ml	750	5-7	2-3	Cut into pieces or slices. Cover. Turn 1 x
Leek	250	50 ml	750	5-7	2-3	
Frozen Brussel sprouts	300	50 ml	750	6-8	2-3	Cover. Turn 1 x
Sauerkraut	250	25 ml	750	8-10	2-3	Cover. Turn 1 x

### Tables and suggestions – Cooking fish

Food	Quantity (g)	Power (Watt)	Time (min.)	Standing Time (min.)	Instructions
Fish fillets	500	550	10-12	3	Cook covered over. Turn after half of cooking time.
Whole fish	800	750 300	2-3 7-9	2-3	Cook covered over. Turn after half of cooking time. You may wish to cover up the small edges of the fish.

## Cooking with the grill

For good results with the grill, use the grid iron supplied with the oven.

**Fit the grid iron in such a way that it doesn't come into contact with the metal surfaces of the oven cavity since if it does there is a danger of electric arcing which may damage the oven.**

### IMPORTANT POINTS:

1. When the microwave grill is used for the first time there will be some smoke and a smell coming from the oils used during oven manufacture.
2. The oven door window becomes very hot when the grill is working. **Keep children away.**
3. When the grill is operating, the cavity walls and the grid iron become very hot. You should use oven gloves.

4. If the grill is used for extended period of time it is normal to find that the elements will switch themselves off temporarily due to the safety thermostat.
5. **Important!** When food is to be grilled or cooked in containers you must check that the container in question is suitable for microwave use. See the section on types of ovenware!
6. When the grill is used it is possible that some splashes of fat may go onto the elements and be burnt. This is a normal situation and does not mean there is any kind of operating fault.
7. After you have finished cooking, clean the interior and the accessories so that cooking remains do not become encrusted.

### Tables and suggestions – Grill without microwave

Fish	Quantity (g)	Time (min.)	Instructions
Fish			
Bass	800	18-24	Spread lightly with butter. After half of cooking time turn and spread with seasoning.
Sardines/gurnard	6-8 fish.	15-20	
Meat			
Sausages	6-8 units	22-26	Halfway through, pierce and turn over.
Frozen hamburgers	3 units	18-20	Turn over 2 or 3x
Spare rib (approx. 3 cm thick)	400	25-30	Baste with oil, turn over halfway through
Others			
Toast	4 units	1½-3	Keep an eye on the toasting process, turn over
Toasted sandwiches	2 units	5-10	Keep an eye on the toasting process.

Heat up the grill beforehand for 2 minutes. Unless indicated otherwise, use the grid iron. Place the grid on a bowl so that the water and the fat can drop.

The times shown are merely indicative and can vary as a function of the composition and quantity of the food, as well as the final condition wished for. Fish and meat taste great if, before grilling, you brush them with vegetable oil, spices and herbs and leave to marinate for a few hours. Only add salt after grilling.

Sausages will not burst if you prick them with a fork before grilling.

After half the grilling time has passed, check on how the cooking is going and, if necessary, turn the food over.

The grill is especially suitable for cooking thin portions of meat and fish. Thin portions of meat only need to be turned once, but thicker portions should be turned several times.

## Cooking with the Grill

### Tables and suggestions – Microwave + Grill

The microwave + grill function is ideal for cooking quickly and, at the same time, browning foods. Furthermore, you can also grill and cook cheese covered food. The microwave and

the grill work simultaneously. The microwave cooks and the grill toasts.

Food	Quantity (g)	Dish	Power (Watt)	Time (min.)	Standing time (min.)
Cheese topped pasta	500	Low dish	300	12-17	3-5
Cheese topped potatoes	800	Low dish	550	20-22	3-5
Lasagne	approx. 800	Low dish	550	15-20	3-5
Grilled cream cheese	approx. 500	Low dish	300	18-20	3-5
2 fresh chicken legs (grilled)	200 each	Low dish	300	10-15	3-5
Chicken	approx. 1000	Low and wide dish	300	35-40	3-5
Cheese topped onion soup	2 x 200 g cups	Soup bowls	300	2-4	3-5

Before using a dish in the microwave oven make sure that it is suitable for microwave use. Only use dishes or containers that are suitable for microwave use.

The dish to be used in the combined function must be suitable for microwave and grill use. See the section on types of ovenware!

Keep in mind that the figures given are merely indicative and can vary as a function of the initial state, temperature, moisture and type of food.

If the time is not enough to brown the food well, put it under the grill for another 5 or 10 minutes.

Please follow the standing times and don't forget to turn the meat pieces.

Unless indicated to the contrary, use the turntable plate for cooking.

The values given in the tables are valid when the oven cavity is cold (it is not necessary to pre-heat the oven).

## What kind of ovenware can be used?

### Microwave function

For the microwave function, keep in mind that microwaves are reflected by metal surfaces. Glass, china, clay, plastic, and paper let microwaves pass.

For this reason, **metal pans and dishes or containers with metal parts or decorations cannot be used in the microwave**. Glass ware and clay with **metallic decoration or content** (e.g. lead crystal) cannot be used in microwave ovens.

The **ideal** materials for use in microwave ovens are glass, refractory china or clay, or heat resistant plastic. Very thin, fragile glass or china should only be used for short period of times (e.g. heating).

Hot food transmits heat to the dishes which can become very hot. You should, therefore, always use an **oven glove!**

### How to test ovenware you want to use

Put the item you want to use in the oven for 20 seconds at maximum microwave power. After that time, if it is cold and just slightly warm, it is suitable to use. However, if it heats up a lot or causes electric arcing it is not suitable for microwave use.

### Grill function

In the case of the grill function, the ovenware must be resistant to temperature of at least 300°C.

Plastic dishes are not suitable for use in the grill.

### Microwave + Grill function

In the microwave + grill function, the ovenware used must be suitable for use in both the microwave and the grill.

### Aluminium containers and foil

Pre-cooked food in aluminium containers or in aluminium foil can be put in the microwave if the following aspects are respected:

- Keep in mind the manufacturer's recommendations written on the packaging.
- The aluminium containers cannot be more than 3 cm high or come in contact with the cavity walls (**minimum distance 3 cm**). Any aluminium lid or top must be removed.
- Put the aluminium container directly on top of the turntable plate. If you use the grid iron, put the container on a china plate. Never put the container directly on the grid iron!
- The cooking time is longer because the microwaves only enter the food from the top. If you have any doubts, it is best to use only dishes suitable for microwave use.
- Aluminium foil can be used to reflect microwaves during the defrosting process. Delicate food, such as poultry or minced meat, can be protected from excessive heat by covering the respective extremities/edges.
- **Important:** aluminium foil cannot come into contact with the cavity walls since this may cause electrical arcing.

### Lids

We recommend you use glass or plastic lids or cling film since:

1. This will stop excessive evaporation (mainly during very long cooking times);
2. The cooking times are shorter;
3. The food does not become dry;
4. The aroma is preserved.

The lid should have holes or openings so that no pressure develops. Plastic bags must also be opened. Baby feeding bottles or jars with baby food and similar containers can only be heated without their tops / lids otherwise they can burst.

## What kind of ovenware can be used?

### Table of Ovenware

The table below gives you a general idea of what type of ovenware is suitable for each situation.

Operating mode Type of ovenware	Microwave		Grill	Microwave + Grill
	Defrosting / heating	Cooking		
<b>Glass and china 1)</b> Home use, not flame resistant, can be used in dish washer	yes	yes	no	no
<b>Glazed china</b> Flame resistant glass and china	yes	yes	yes	yes
<b>China, stone ware 2)</b> Unglazed or glazed without metallic decorations	yes	yes	no	no
<b>Clay dishes 2)</b> Glazed	yes	yes	no	no
Unglazed	no	no	no	no
<b>Plastic dishes 2)</b> Heat resistant to 100°C	yes	no	no	no
Heat resistant to 250°C	yes	yes	no	no
<b>Plastic films 3)</b> Plastic film for food	no	no	no	no
Cellophane	yes	yes	no	no
<b>Paper, cardboard, parchment 4)</b>	yes	No	no	no
<b>Metal</b> Aluminium foil	yes	no	yes	no
Aluminium wrappings 5)	no	yes	yes	yes
Accessories	yes	yes	yes	yes

- Without any gold or silver leaf edging; no lead crystal.
- Keep the manufacturer's instructions in mind!
- Do not use metal clips for closing bags. Make holes in the bags. Use the films only to cover the food.
- Do not use paper plates.
- Only shallow aluminium containers without lids/tops. The aluminium cannot come into contact with the cavity walls.

## Oven Cleaning and Maintenance

Cleaning is the only maintenance normally required.

**Warning!** Your microwave oven should be cleaned regularly, with all food remains being removed. If the microwave is not kept clean its surfaces may deteriorate, **reducing the oven's working life and possibly resulting in a dangerous situation.**

**Warning!** Cleaning should be done with the oven power switched off. Take the plug out of the socket or switch off the oven's power circuit.

**Do not use aggressive or abrasive cleaning products, scourers that scratch surfaces or sharp objects, since stains may appear.**

**Do not use high pressure or stream jet cleaning appliances.**

### Front surface

Normally you just need to clean the oven with a damp cloth. If it is very dirty, add a few drops of dishwashing liquid to the cleaning water. Afterwards, wipe the oven with a dry cloth.

**In an oven with an aluminium front,** use a glass cleaning product and a soft cloth that does not release any fibres or threads. Wipe from side to side without exerting any pressure on the surface.

Immediately remove lime, fat, starch or egg white stains. Corrosion can occur under these stains.

Do not let any water get inside the oven.

### Oven interior

After each time the oven is used, clean the inside walls with a damp cloth since this is the easiest way to remove splashes or spots of food that may have stuck to the inside.

To remove dirt that is harder to shift, use a non-aggressive cleaning product. **Do not use oven sprays or other aggressive or abrasive cleaning products.**

**Always keep the door and the oven front very clean to ensure that the door opens and closes properly.**

Make sure water does not enter the microwave ventilation holes.

Regularly take out the turntable plate and the respective support and clean the cavity base, especially after any liquid spillage.

**Do not switch on the oven without the turntable and the respective support being in place.**

If the oven cavity is very dirty, put a glass of water on the turntable and switch on the microwave oven for 2 or 3 minutes at maximum power. The steam released will soften the dirt which can then be cleaned easily using a soft cloth.

Unpleasant odours (e.g. after cooking fish) can be eliminated easily. Add a few drops of lemon juice or vinegar in a cup of water. Put a spoonful of coffee in the cup to avoid the water boiling over. Heat the water for 2 to 3 minutes at maximum microwave power.

## Oven Cleaning and Maintenance

### Oven ceiling

If the oven ceiling is dirty, the grill can be lowered to make cleaning easier.

**To avoid the danger of burning, wait until the grill is cold before lowering it.**

Proceed as follows:

1. Turn the grill support by 180° (1).
2. Lower the grill gently (2). **Do not use excessive force as this may cause damage.**
3. After cleaning the ceiling, put the grill (2) back in its place, carrying out the previous operation.

**IMPORTANT WARNING:** The grill heating element support (1) may fall when it is rotated. If this happens, insert the grill heating element support (1) into the slot in the ceiling of the cavity and rotate it 90° to the grill heating element support (2) position.

**The mica cover (3) located in the ceiling must always be kept clean.** Any food remains that collect on the mica cover can cause damage or provoke sparks.

**Do not use abrasive cleaning products or sharp objects.**

**To avoid any risk, do not remove the mica cover.**

The glass lamp cover (4) is located on the oven ceiling and can be removed easily for cleaning. For this you just need to unscrew it and clean it with water and dishwashing liquid.

### Accessories

Clean the accessories after each use. If they are very dirty, soak them first of all and then use a brush and sponge. The accessories can be washed in a dish washing machine.

Make sure that the turntable plate and the respective support are always clean. Do not switch on the oven unless the turntable and the respective support are in place.

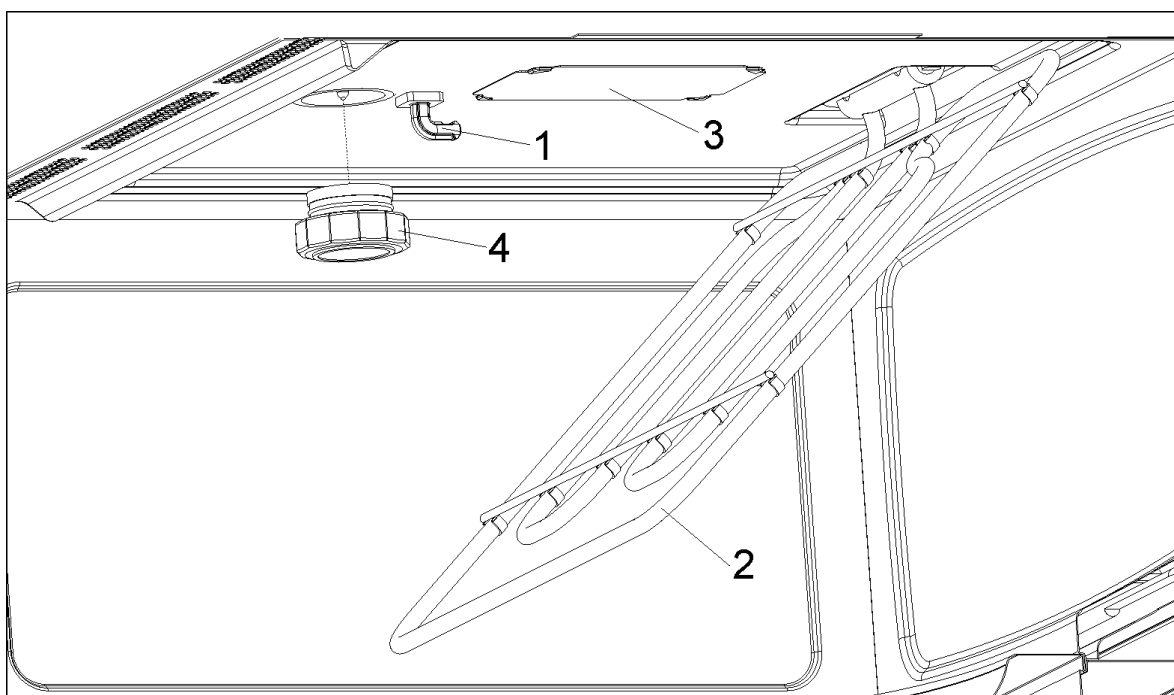

## What should I do if the oven doesn't work?

**WARNING!** Any type of repair must only be done by a specialised technician. Any repair done by a person not authorised by the manufacturer is dangerous.

You do not need to contact Technical Assistance to resolve the following questions:

- **The display is not showing!** Check if:
  - The time indication has been switched off (see section on Basic Settings).
- **Nothing happens when I press the keys!** Check if:
  - The Safety Block is active (see section on Basic Settings).
- **The oven does not work!** Check if:
  - The plug is correctly fitted in the socket.
  - The oven's power is switched on.
  - The door is completely closed. The door should close with an audible click.
  - There are any foreign bodies between the door and the cavity front.
- **When the oven is operating I can hear some strange noises!** Check if:
  - There is any electrical arcing inside the oven caused by foreign metallic objects (see section on type of ovenware).
  - The ovenware is touching the oven walls.
  - There are any loose items of cutlery or cooking tools inside the oven.
- **The food doesn't heat up or heats very slowly!** Check if:
  - You have inadvertently used metal ovenware.
  - You have selected the correct operating times and power level.
  - The food you have put inside the oven is a larger amount or colder than you usually put in.

- The food is too hot, dried out or burnt! Check if you selected the correct operating time and power level.
- I hear some noises after the cooking process is finished! This is not a problem. The cooling fan keeps on working for some time. When the temperature has dropped sufficiently, the fan will switch itself off.
- The oven switches on but the interior light does not go on! If all the functions work properly it is probable that the lamp has blown. You can keep on using the oven.

### Substitution of light bulb

To substitute the light bulb, proceed as follows:

- Disconnect the oven from the power supply. Take the plug out of the socket or switch off the oven's power circuit.
- Unscrew and remove the glass light cover (1).
- Remove the halogen light bulb (2). **Warning! The bulb may be very hot.**
- Fit a new 12V / 10W halogen bulb. **Warning! Do not touch the light bulb surface directly with your fingers because you may damage the bulb.** Follow the lamp manufacturer's instructions.
- Screw the glass light cover into place (1).
- Connect the oven again to the power supply.

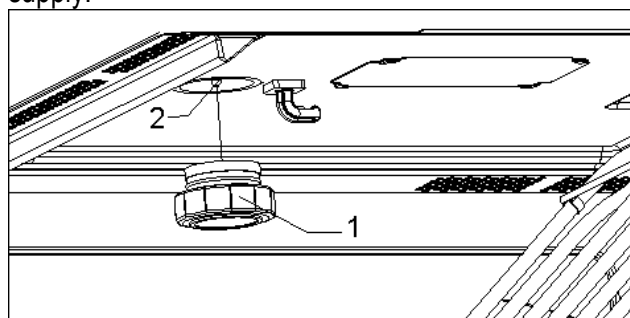



## Technical characteristics

### Specifications

- AC Voltage..... 230-240 V / 50 Hz
- Power required..... 3300 W
- Grill power..... 1500 W
- Microwave output power..... 1000 W
- Microwave frequency ... 2450 MHz
- Exterior dimensions (W×H×D)..... 595 × 455 × 472 mm
- Interior dimensions (W×H×D)..... 420 × 210 × 390 mm
- Oven capacity..... 32 l
- Weight..... 35 kg

## Environmental protection

### Disposal of the packaging

The packaging bears the Green Point mark.

Dispose of all the packaging materials such as cardboard, expanded polystyrene and plastic wrapping in the appropriate bins. In this way you can be sure that the packaging materials will be re-used.



### Disposal of equipment no longer used

According to European Directive 2002/96/EC on the management of waste electrical and electronic equipment

(WEEE), home electrical appliances should not be put into the normal systems for disposal of solid urban waste.

Outdated appliances should be collected separately to optimise component material recovery and re-cycling rates and to prevent potential harm to human health and the environment. The symbol of a rubbish container superimposed by a diagonal cross should be put on all such products to remind people of their obligation to have such items collected separately.

Consumers should contact their local authorities or point of sale and request information on the appropriate places to leave their old home electrical appliances.

Before disposing of your appliance, render it non-usable by pulling out the power cable, cutting this and disposing of it

## Installation instructions

### Before installation

**Check that the input voltage** indicated on the characteristics plate is the same as the voltage of the power outlet you are going to use.

Open the oven door and **take out all the accessories** and remove the packing material.

**Do not remove the mica cover** on the ceiling of the interior! This cover stops fat and pieces of food damaging the microwave generator.

**Warning!** The front surface of the oven may be wrapped with a **protective film**. Before using the oven for the first time, carefully remove this film, starting on the inside.

**Make sure that the oven is not damaged in any way.** Check that the oven door closes correctly and that the interior of the door and the front of the oven opening are not damaged. If you find any damage contact the Technical Assistance Service.

**DO NOT USE THE OVEN** if the power cable or the plug are damaged, if the oven does not function correctly or if it has been damaged or dropped. Contact the Technical Assistance Service.

Put the oven on a flat and stable surface. The oven must not be put close to any sources of heat, radios or televisions.

**During installation, make sure that the power cable does not come into contact with any moisture or objects with sharp edges behind the oven.** High temperatures can damage the cable.

**Warning:** after the oven is installed you must make sure you can access the plug.

### After installation

The oven is equipped with a power cable and a plug for single phase current.

**If the oven is to be installed on a permanent basis** it should be installed by a qualified technician. In such a case, the oven should be connected to a circuit with an all-pole circuit breaker with a minimum separation of 3 mm between contacts.

**WARNING: THE OVEN MUST BE EARTHED.**

**The manufacturer and retailers do not accept responsibility** for any damage that may be caused to people, animals or property if these installation instructions are not observed.

**The oven only functions** when the door is closed correctly.

After the first use, clean the inside of the oven and the accessories, following the cleaning instructions given in the section "Oven cleaning and maintenance".

Fit the Turntable support in the centre of the oven cavity and put the Turntable ring and the Turntable plate on top, making sure they slot in. Whenever you use the microwave, the turntable plate and the respective accessories must be inside and correctly fitted. **The turntable plate can rotate in both directions.**

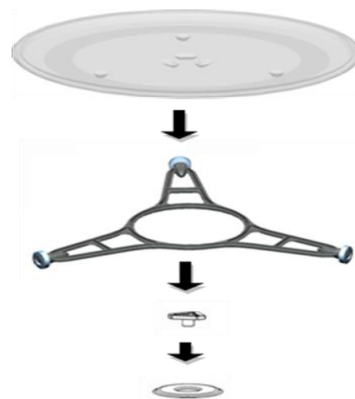

**During installation, follow the instructions supplied separately.**

## Einbau / Installation

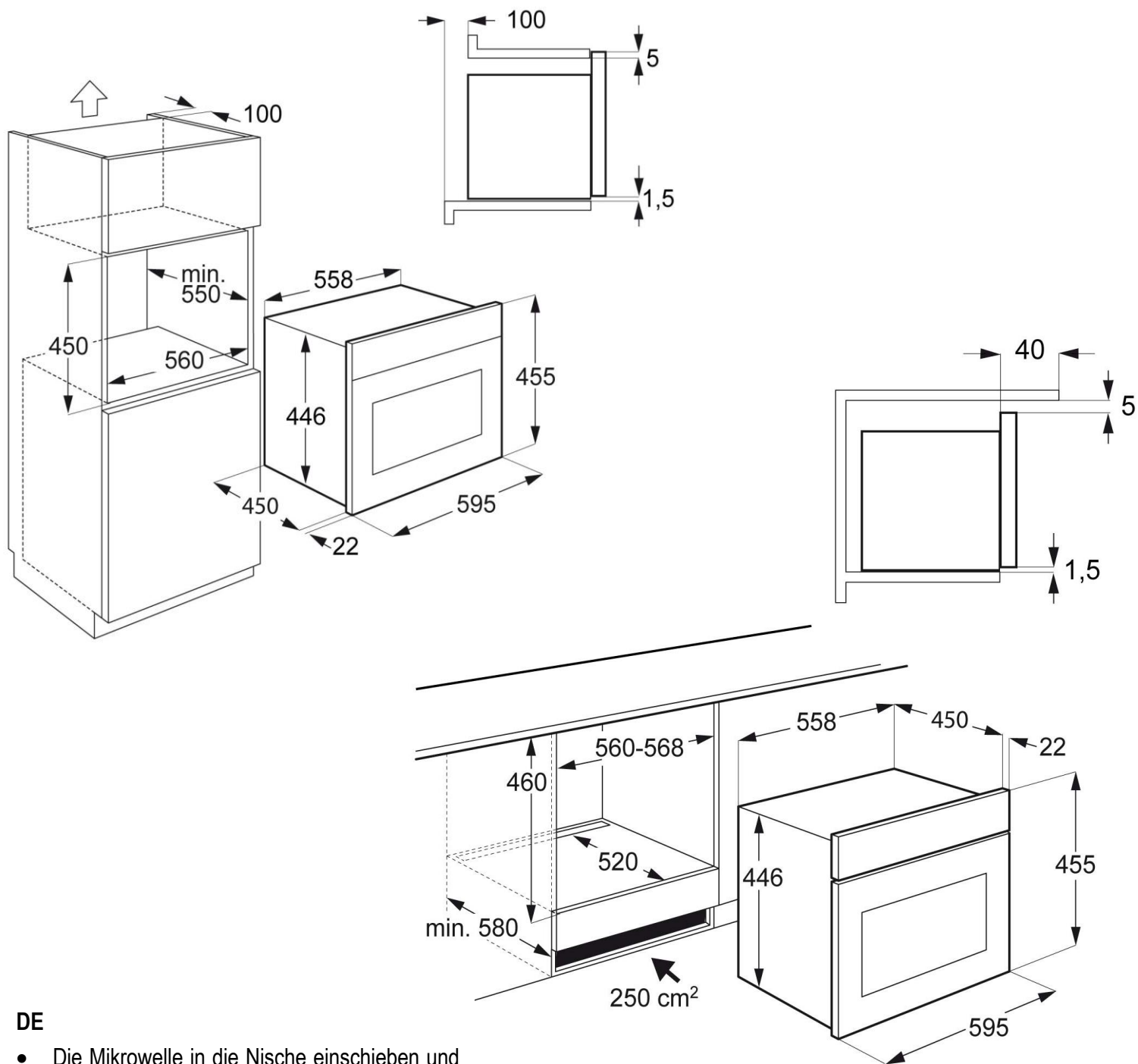

### DE

- Die Mikrowelle in die Nische einschieben und entsprechend anpassen.
- Die Tür der Mikrowelle öffnen und das Gerät mit den vier mitgelieferten Schrauben am Küchenmöbel wie im Bild dargestellt befestigen.

### EN

- Push oven completely into the cabinet and centre it.
- Open microwave door and fasten the appliance to the cabinet using the four screws provided. Insert the screws through the front holes.

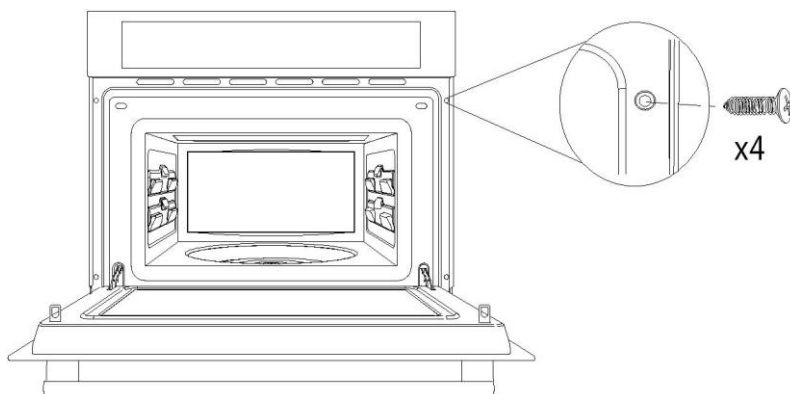





Küppersbusch Hausgeräte GmbH  
Postfach 10 01 32, D-45801 Gelsenkirchen, Küppersbuschstr. 16, D-45883 Gelsenkirchen  
Telefon: (02 09) 4 01-0, Telefax: (02 09) 4 01-3 03  
[www.kueppersbusch.de](http://www.kueppersbusch.de)

Teka Austria GmbH  
Eitnergasse 13, A-1230 Wien  
Telefon: (01) 8 66 80-15, Telefax: (01) 8 66 80-50  
[www.kueppersbusch.at](http://www.kueppersbusch.at)